

Products	3.0
Application examples for Support Brackets (Sikla-CAD-library)	3.1
Support Bracket WK 100/100,, WK 200/200 with reinforcement indents for extra support	3.2
Support Bracket WK 300/200,, WK 880/550 made of C-Section steel	3.3
Socket Angles for bracing Cantilevers	3.4
Support Cone SMD 1 to create rigid connections	3.5
Fixing Brackets for special solutions and various fixings	3.6
Joint JOI V - HCP and JOI 41 T - HCP for Channel MS 41	3.7
SFK Bracket for SML Pipes of DN 100 - DN 150	3.8

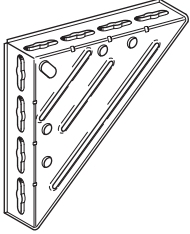

Products

Support Bracket WK 100/100
150/150
200/200



Support Bracket WK 300/200
550/350

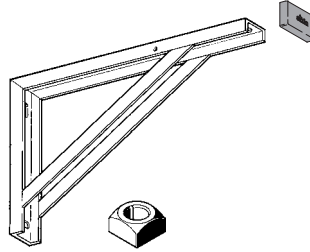

Support Bracket WK 725/400
880/550

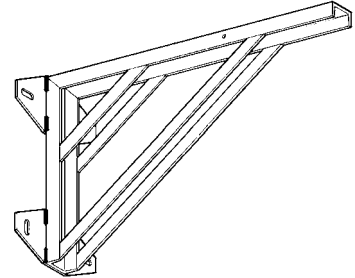

Tie Rod STR

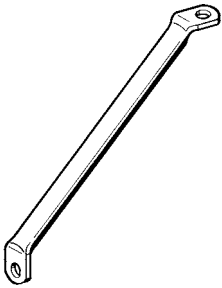

Fixing Bracket MW S

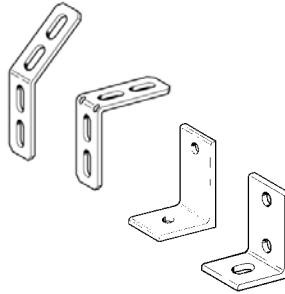

Cantilever Bracket AK

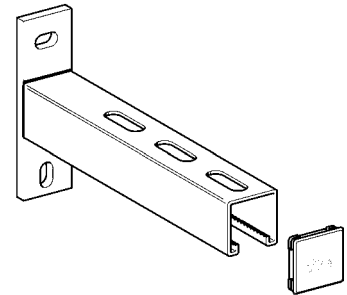

Socket Angle ST

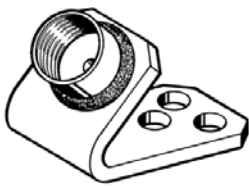

Support Cone SMD 1

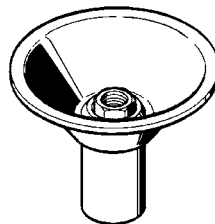

Mounting Plate GPL

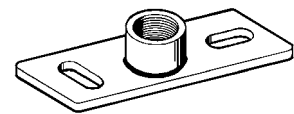

see Fixed Points

Universal Joint JOI 41 V HCP

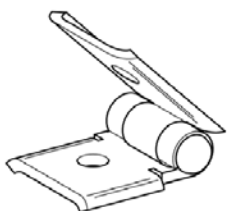

Universal Joint JOI 41 V HCP

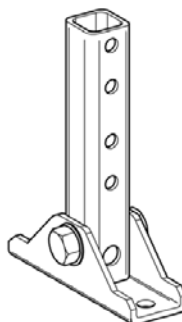

SFK Bracket

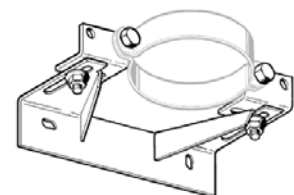

Application examples for Support Brackets (Sikla-CAD-library)

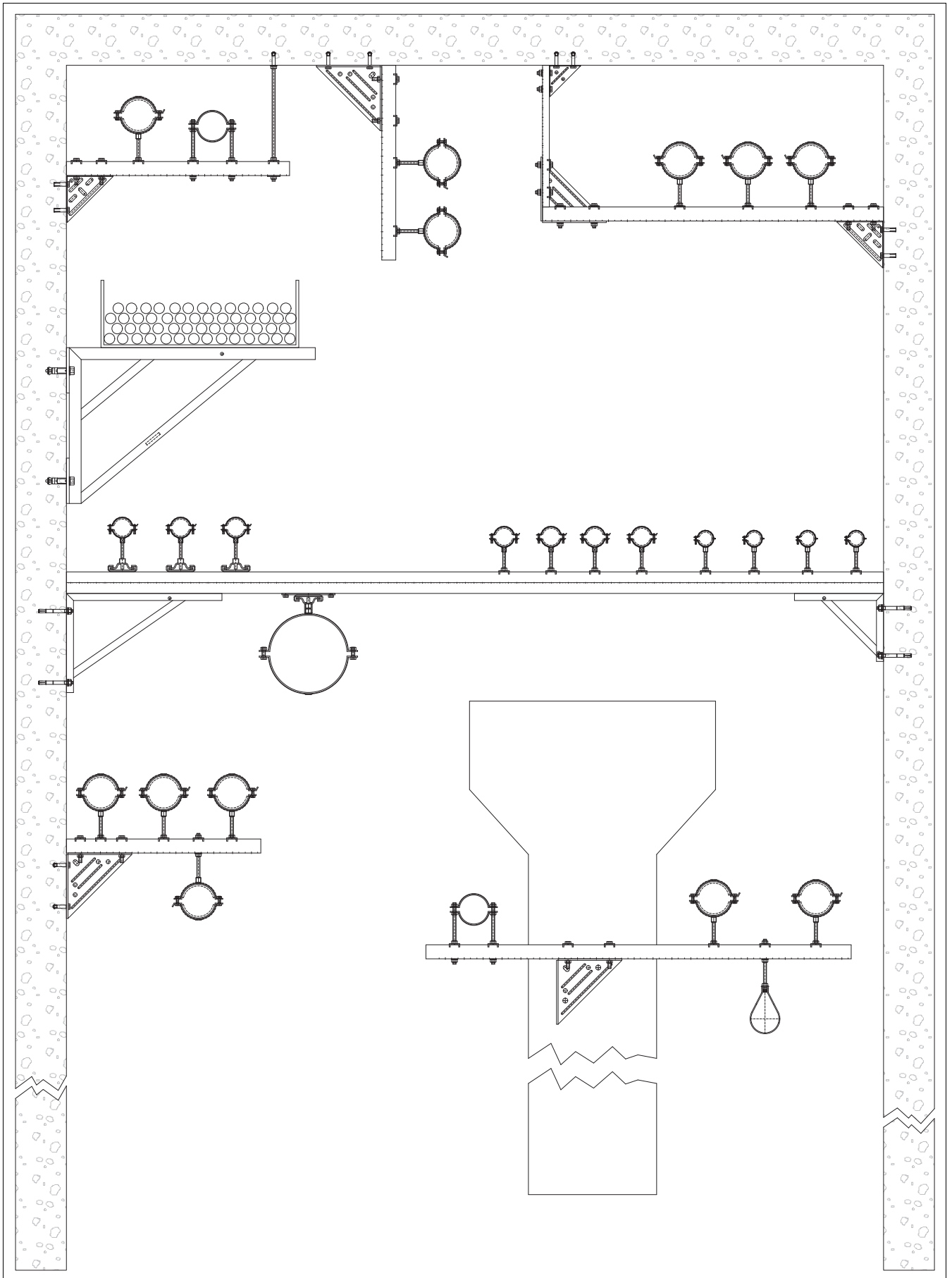

Support Bracket WK 100/100,, WK 200/200 with reinforcement indents for extra support

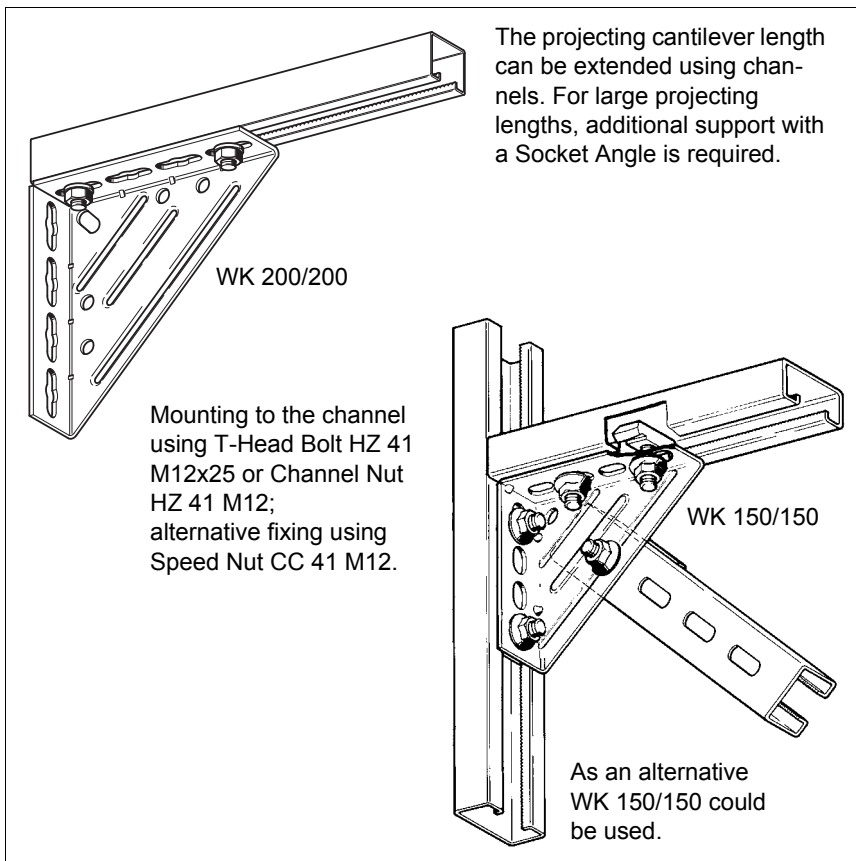
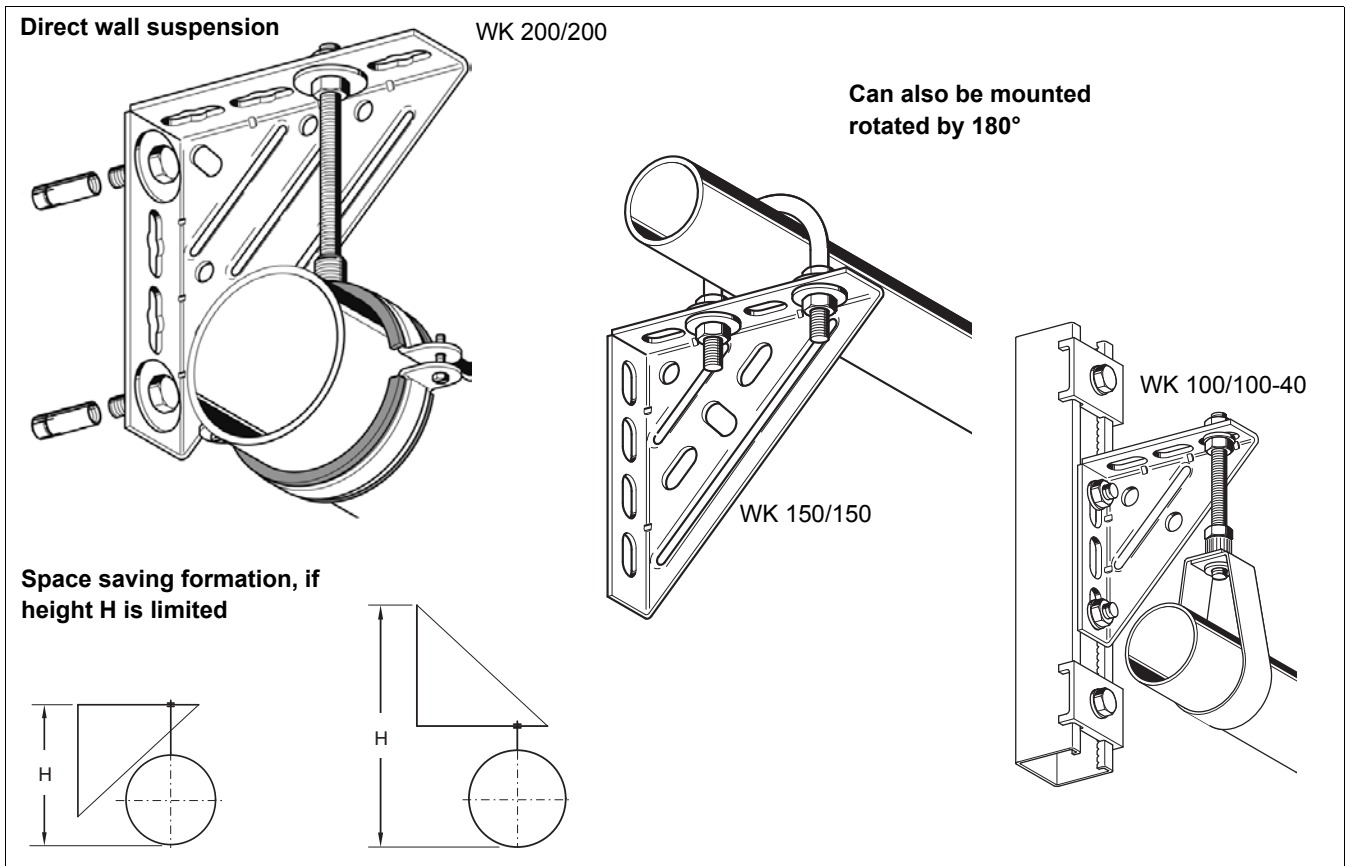

▲ The channel is installed directly to the wall, thus increasing the axial spacing of the fixings, which allows for a higher load capacity.

Support Bracket 150/150 can be used as a webbing plate. The centre hole allows the channel to be fixed at 45 degrees.

Support Bracket WK 300/200,, WK 880/550 made of C-Section steel

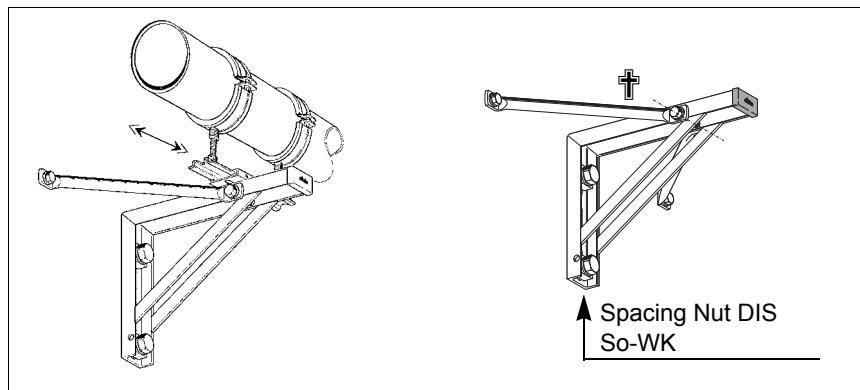
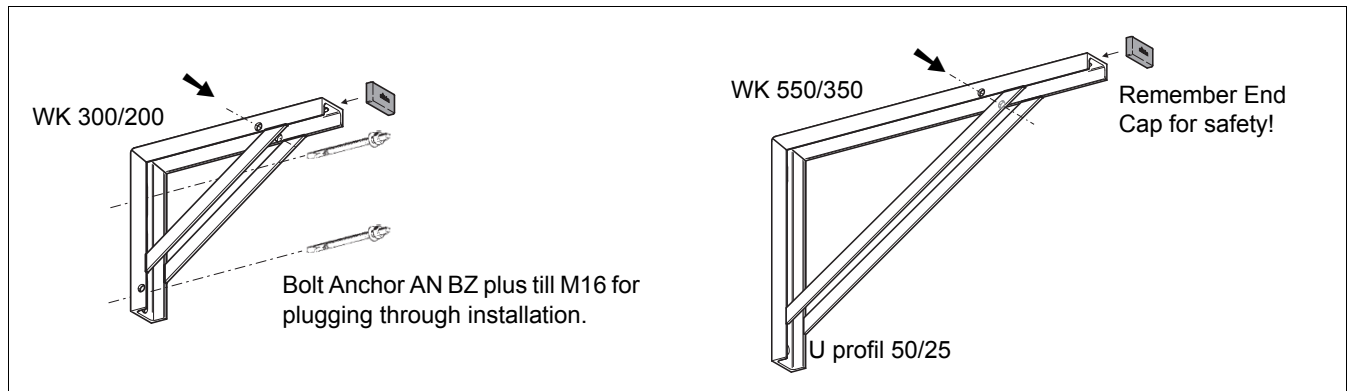

Lateral forces (e.g. due to pipe movement on sliding supports), require lateral Tie Rods (on one or both sides). Pre-drilled connection holes are provided to the sides of the Support Brackets. For all brackets of sizes 300/200,, 880/550 suitable 45 degree Tie Rods are available for each size.

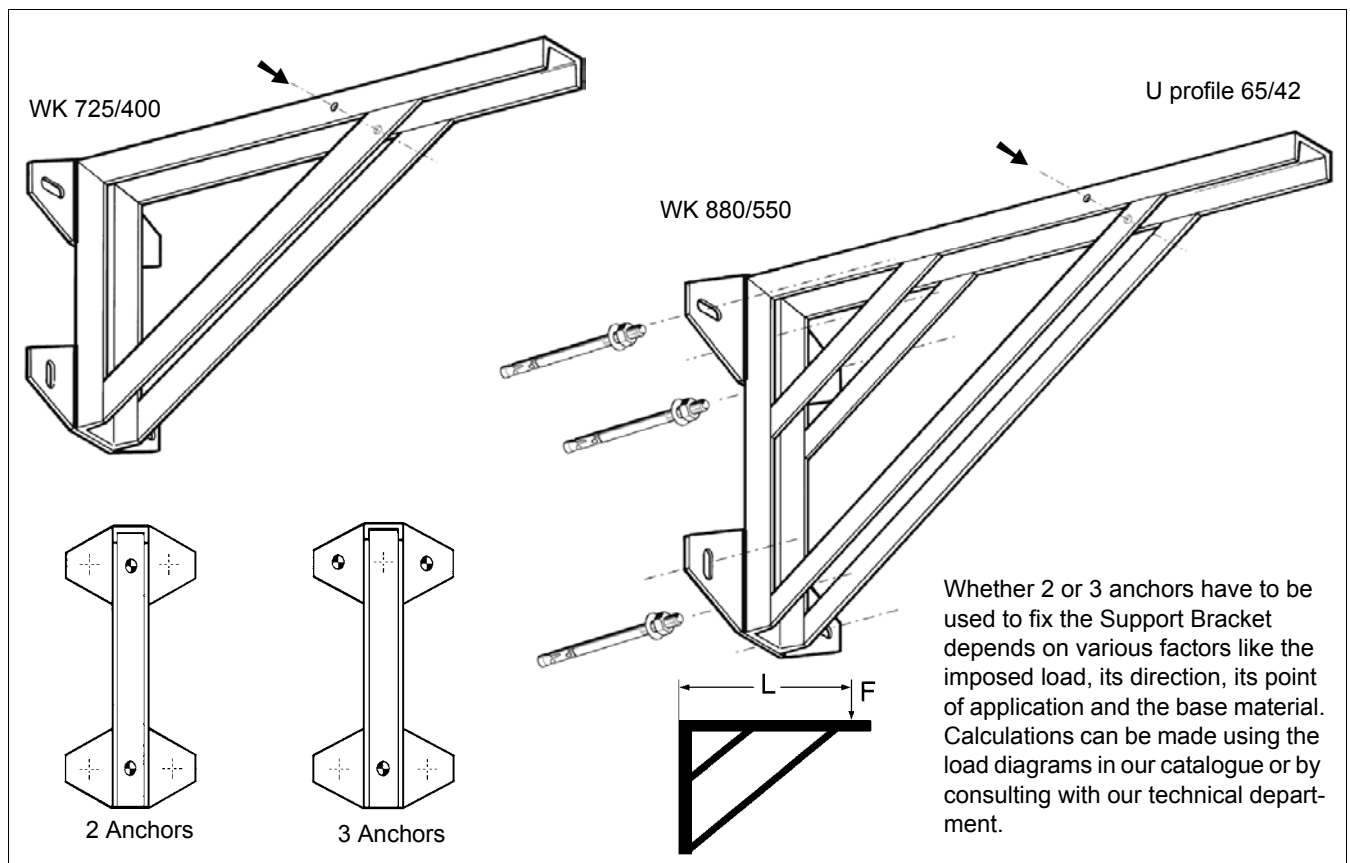

Whether 2 or 3 anchors have to be used to fix the Support Bracket depends on various factors like the imposed load, its direction, its point of application and the base material. Calculations can be made using the load diagrams in our catalogue or by consulting with our technical department.

Socket Angles for bracing Cantilevers

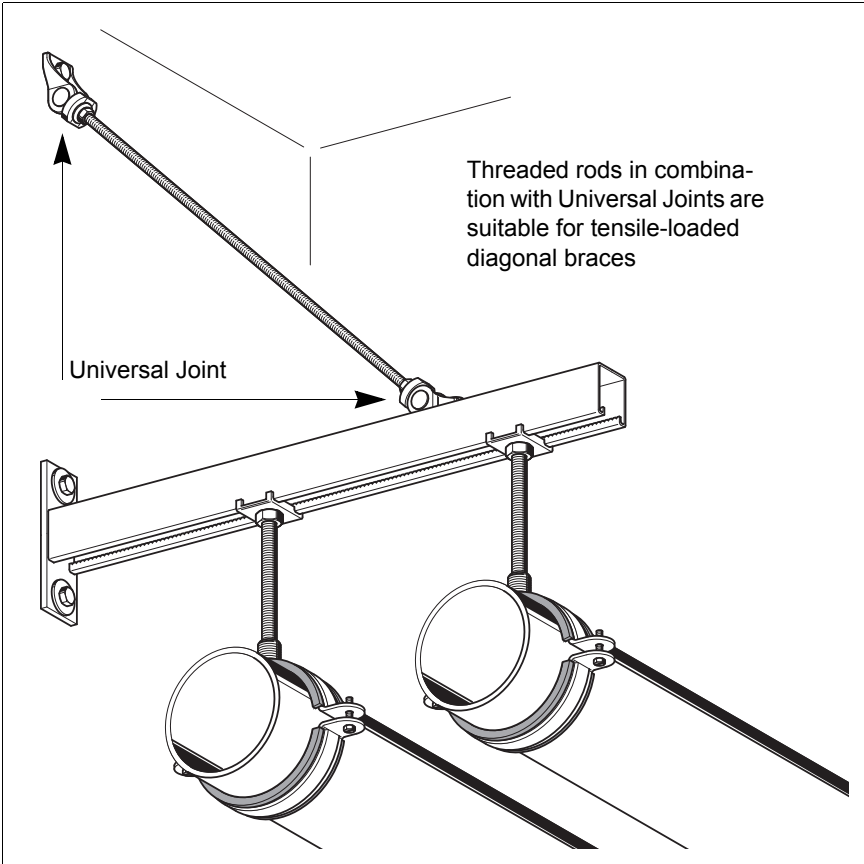

Longer cantilever lengths and / or higher loadings require additional bracing to support the Cantilever Brackets.

Compression loaded braces require a greater cross-sectional area in the bracing element e.g. Sikla Threaded Tubes with Socket Angles.

Socket Angles can also be used as lateral braces to resist lateral loads, in both tension and compression.

Note
 ▶ To resist lateral forces, the installation of a lateral brace is required

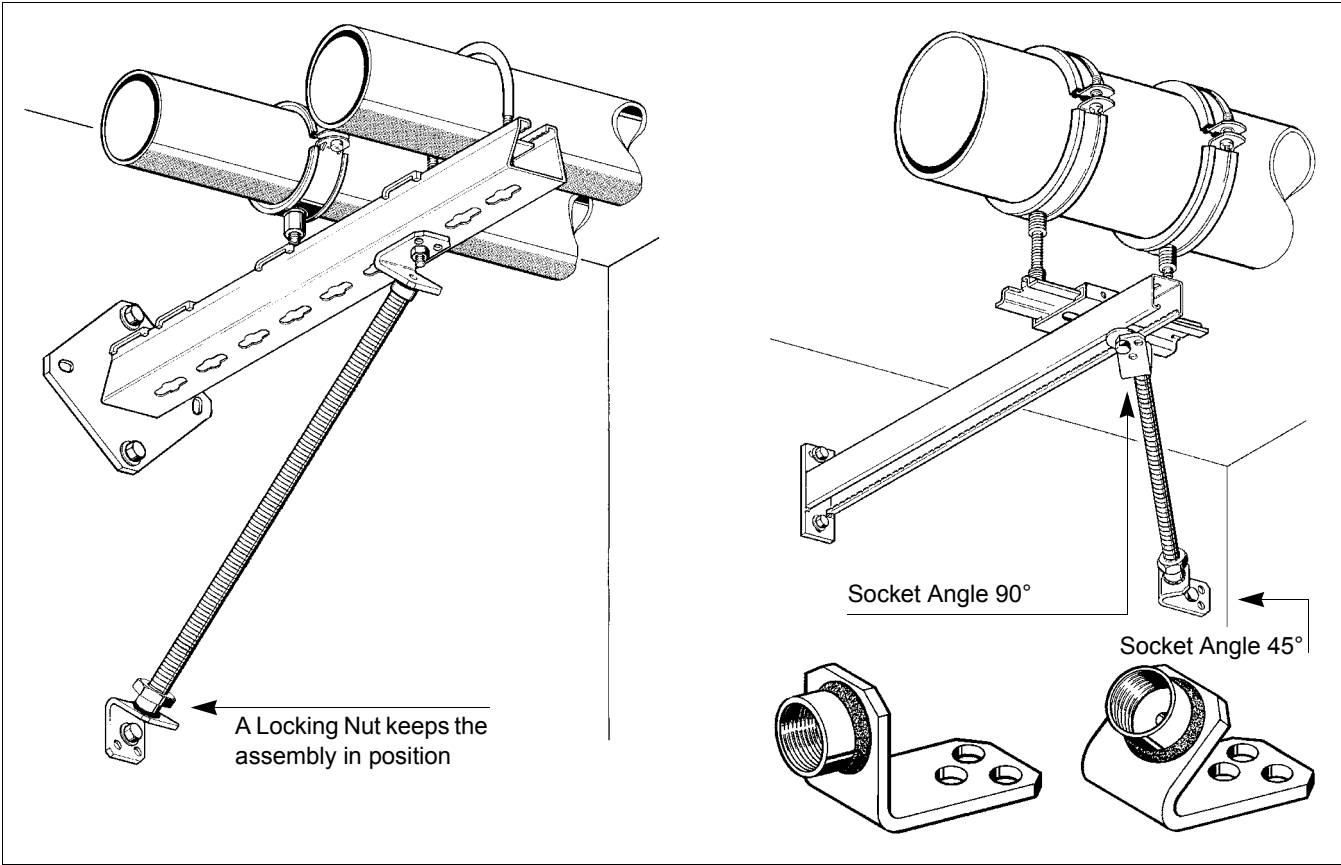

Support Cone SMD 1 to create rigid connections

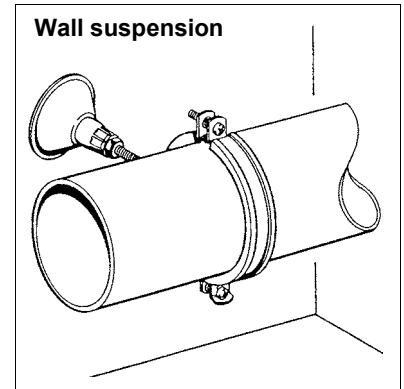
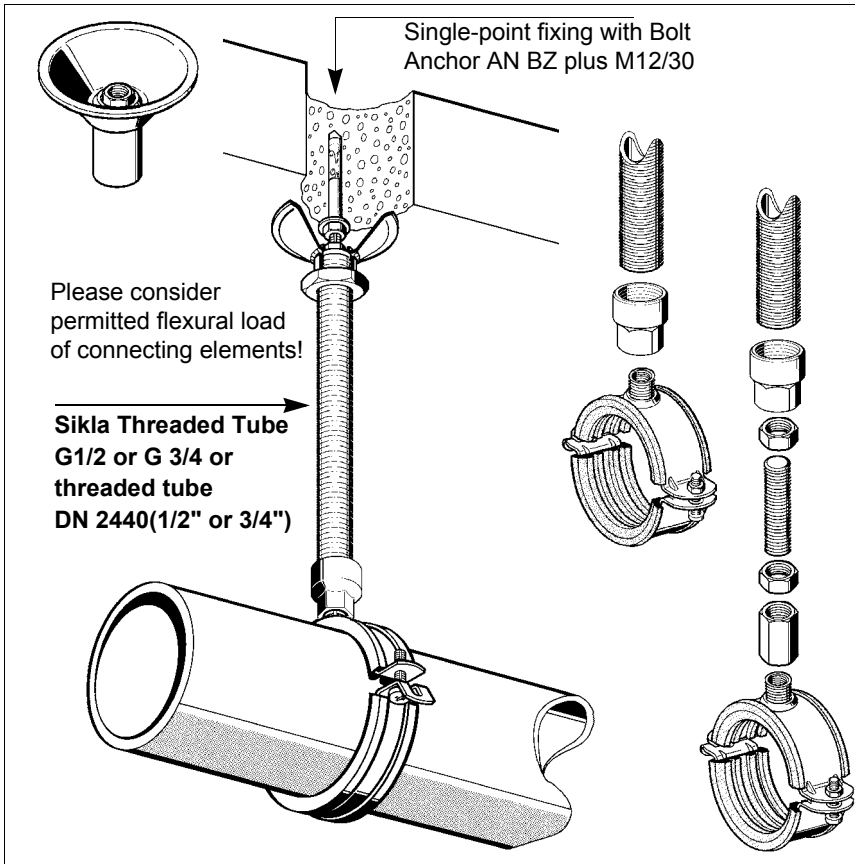

Connection by using Adapter AD to the Triple Thread Nut 3G of Pipe Clamps: Stabil D-3G, Ratio S, Ducting Clamp PLU, Refrigeration Clamp SKS Top-2C.

Connection by using Grub Screw, height adjustable. Free length of the Grub Screw: max. 2 x thread diameter.

Due to the shape, Support Cone SMD 1 can bear the same load in all mounting plane directions.



Ceiling suspension or floor-mounted frame

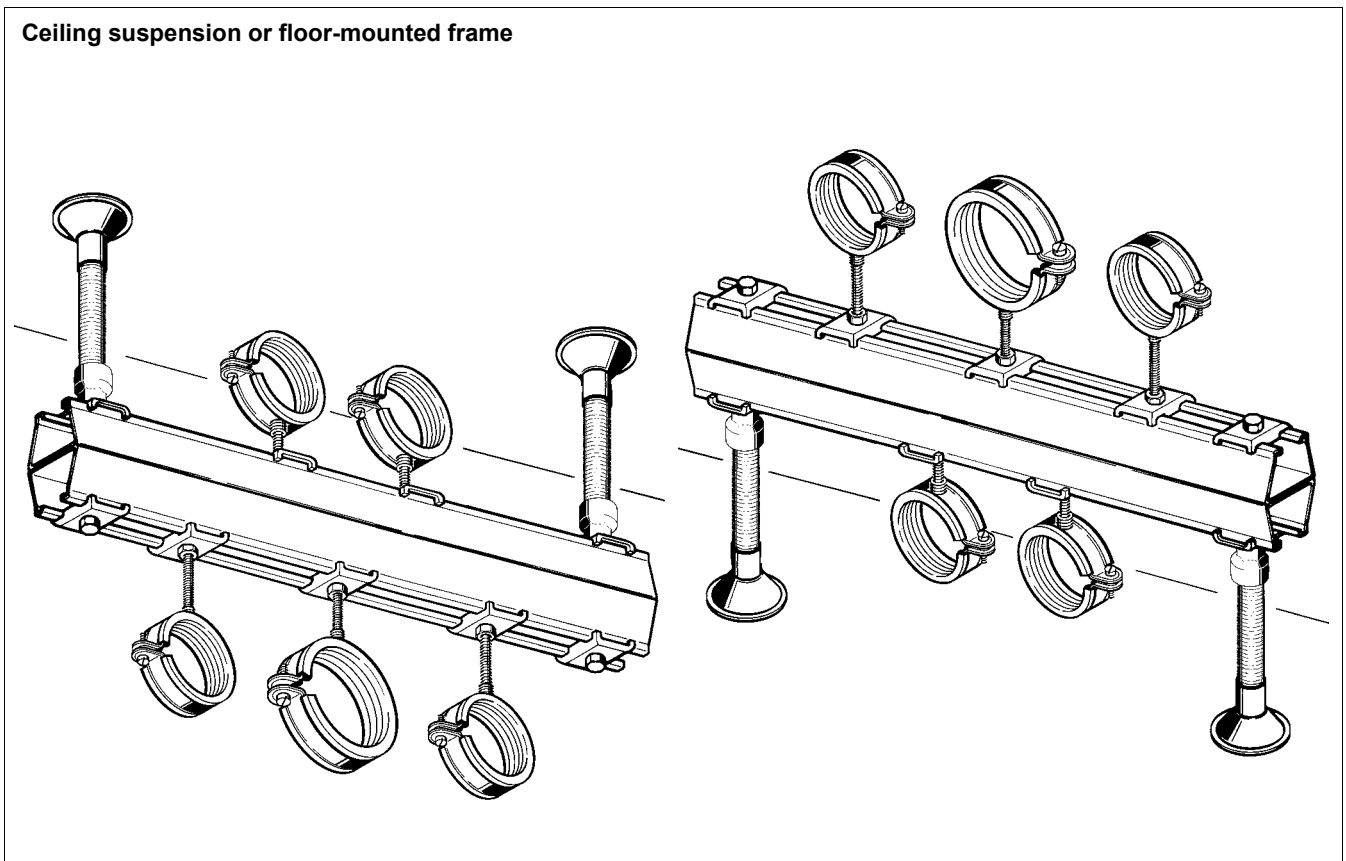

Fixing Brackets for special solutions and various fixings

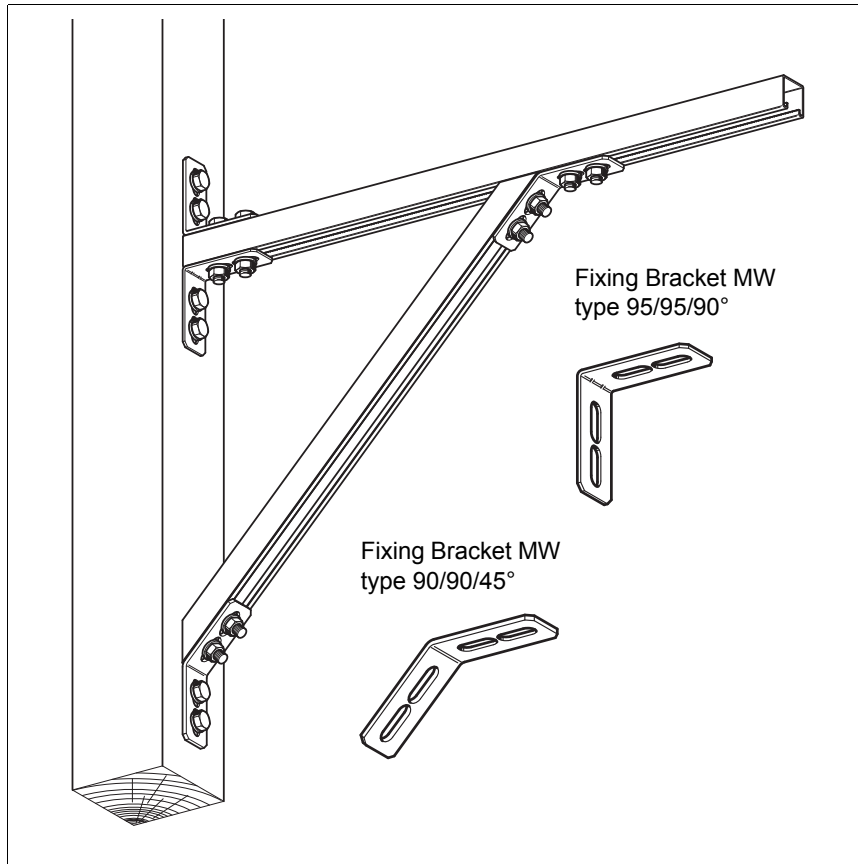

Various fixing brackets, channels and connecting elements enable the construction of diverse special cantilevers.

Note

► The alternative use of appropriate types of angle Connectors CN CC Stabil simplifies the installation.

Fixing Bracket suitable for plant engineering and sprinkler installations.

Caution!

► Consider the regulations for Anchors regarding edge distance a_R .

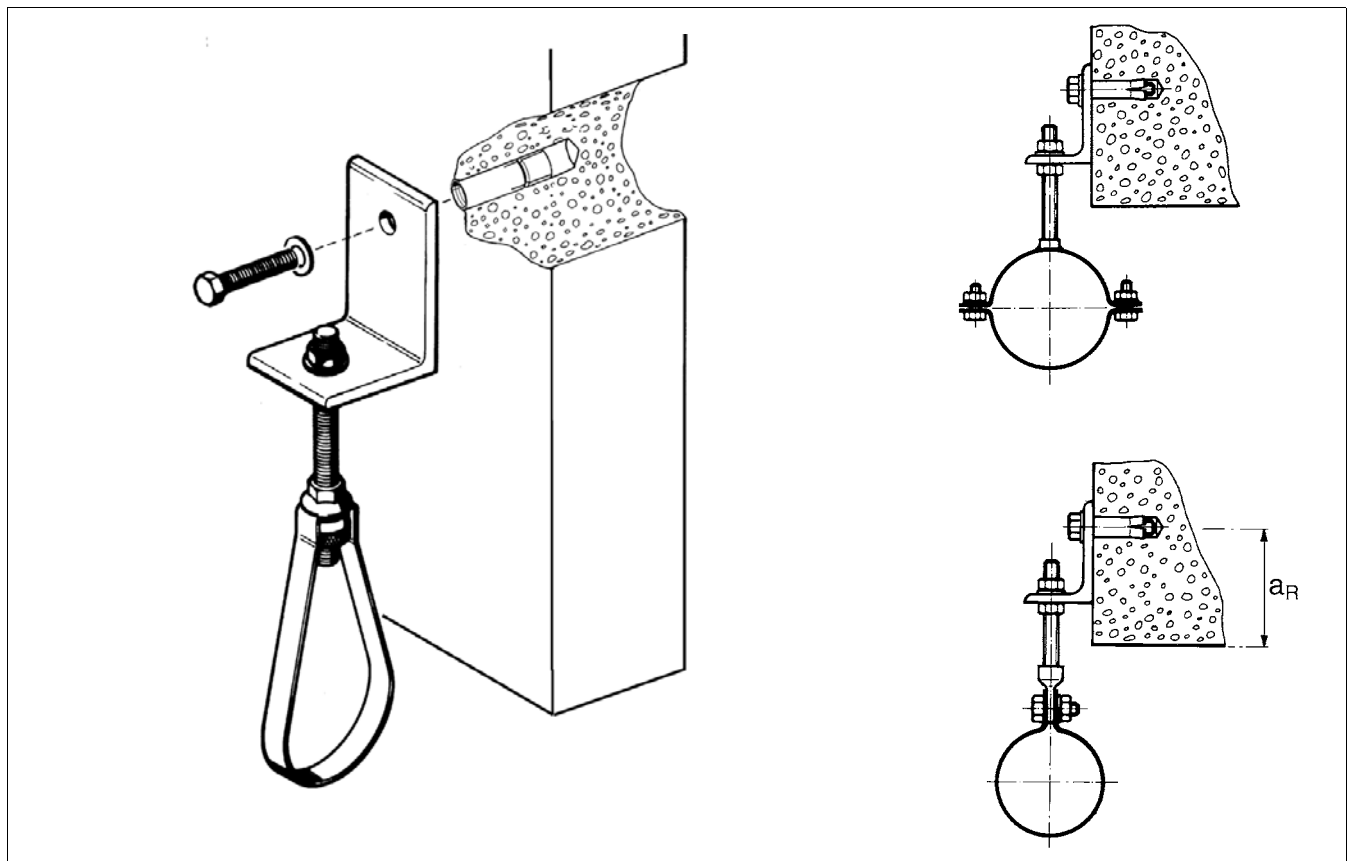

Joint JOI V - HCP and JOI 41 T - HCP for Channel MS 41

Joint JOI V - HCP

Connection through channelslot with Speed Nut NT CC 41-M10 and Hexagon Bolt SKT M10x20, resilient from F_q till 2 kN per connection. Tightening torque 40 Nm

Combination with further HCP-products for optimized system-orientated corrosion protection.

also suitable for M10 to structure connection

Advantages:

- ◆ Suitable for a flexible pivoting connection between channel and building structure or channel and other profile / material.
- ◆ For the connection of channels MS41 with step-less angular adjustment 0...180 degrees, e.g. lateral support of cantilever brackets.
- ◆ When fixing to a sloped surface, level channels can be formed by using the pivot to off-set the gradient of the supporting structure.
- ◆ HCP coating for maximum protection.

HCP

▶ **High Corrosion Protection** corrosion protection equivalent to the level of hot-dipped-galvanising or higher.

Joint JOI 41 T - HCP

Perfect for connecting with further elements in the range Pressix CC 41 channel system.

1 Channelslot orientation is possible in all directions. After unscrewing the thread bolt, the square nut should be turned by 90° and the lock nut will be rescrewed.

2 Quick an secure installation of channels (preferably 41/41/2.5) with 2 Self Forming Screws FLS F 80 at the channel back.

3 On site installation of the base plates with 2 anchors M10 (axial anchor distance 100mm).

SFK Bracket for SML Pipes of DN 100 - DN 150

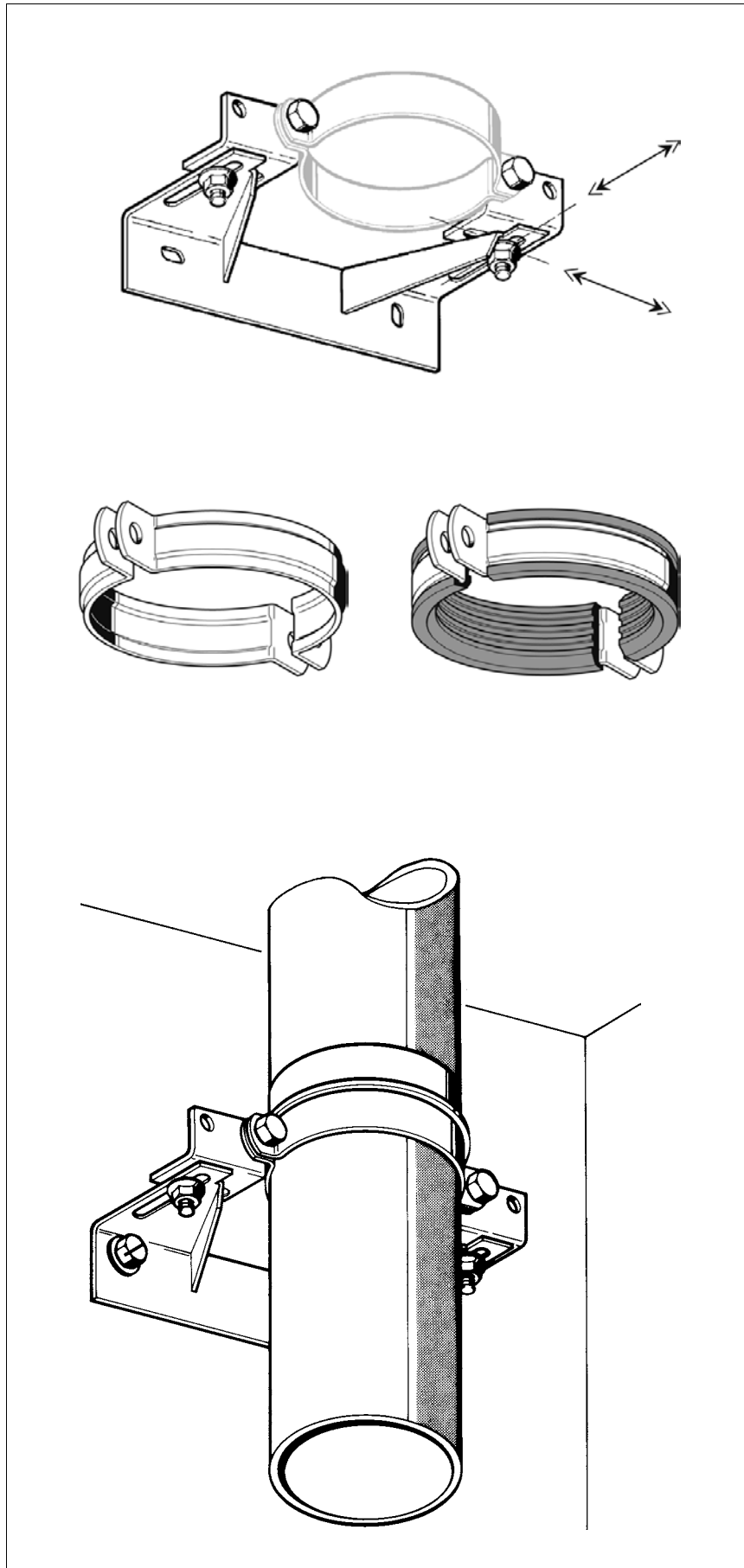

The distance from the wall can be adjusted using the elongated holes in the cantilever.

Elongated slots in the pipe clamp joining brackets allow for adjustment to suit the required width of pipe clamp diameter.

Note

► *The Pipe Clamp must be ordered separately :*

*Stabil D or
Stabil D with Lining*

*for
DN 100
DN 125
DN 150*

Note

► *Nuts and bolts for mounting the Pipe Clamps are supplied with the Bracket.*

