

Products	8.0
Beam Clamp - Single Support	8.1
Universal Joint for any variable Angle Adjustment	8.2
Beam Clamp TCS for Header Rails	8.3
Beam Clip for Cross Support/ Dimensioning of Bolts	8.4
Beam Clip for Cross Member Support	8.5
Beam Clip for Cantilever Support	8.6
Beam Clip for Supports on Building Structures	8.7
U-Holder SB 41	8.8
Threaded Hooks GH for Cross Supports	8.9
Hook Sleeves SP and Bulb Flat Steel Beam Clamp for single supports	8.10
Hook Sleeves and Bulb Flat Beam Clamp for bracket installation	8.11
Clamping End set SKL for Installation to I-beam and C-section profiles between flanges	8.12
Toggle Stud KD for Installation to profiled Metal Decks	8.13
Roof Hangers TRH for Installation to Profiled Metal Decking	8.14
Fixing to Holorib and Cofrastra composite floors	8.15

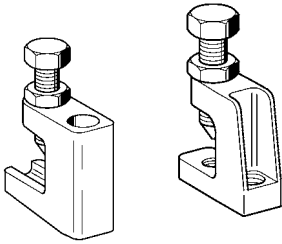

Products

Beam clamp TCS 0



Beam clamp TCS 1/ TCS 2

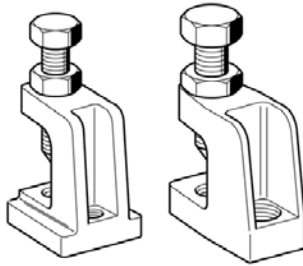

Beam clamp TCS 41

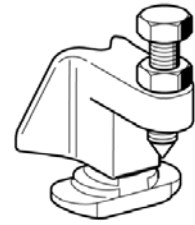

Universal Joint UG

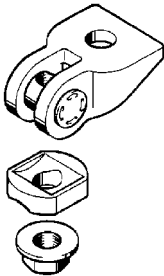

Beam Clip P

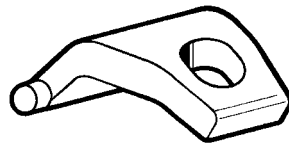

U-Holder SB 41

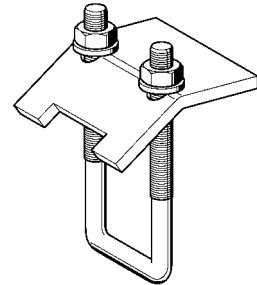

**Threaded Hook GH
Hook Sleeve SP**

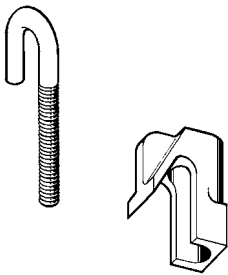

Bulb Flat Steel Beam Clamp

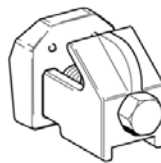

Clamping End SKL

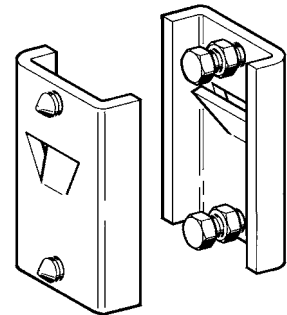

**Toggle Stud
KD**

**Hole Saw
LS**

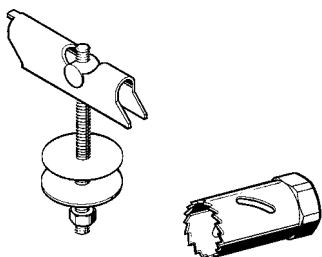

**Roof Hanger
TRH**

**Piercing Tool
LOT**

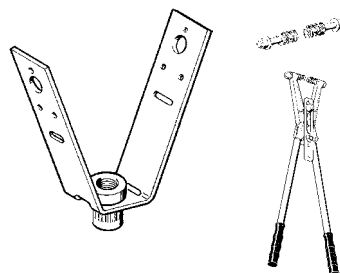

**Wedge Bolt
KB**

**Clamp
VBO C 40**

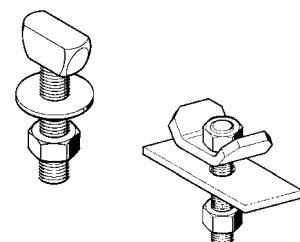

Beam Clamp - Single Support

Basic application

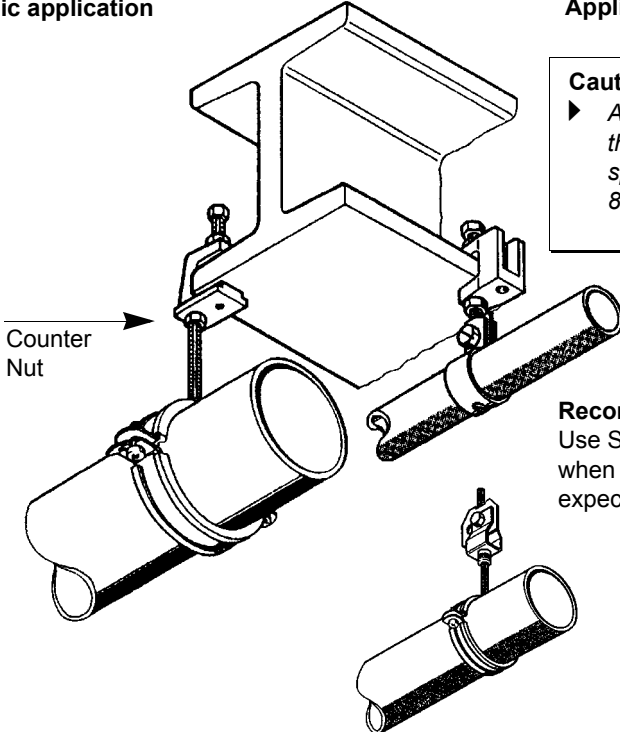

Counter Nut

Application with Safety Strap

Caution!

► According to VdS-directive the use of the Safety Strap is specified for pipes from DN 80 onwards!

Recommendation:
Use Safety Strap also, when vibrations are expected.

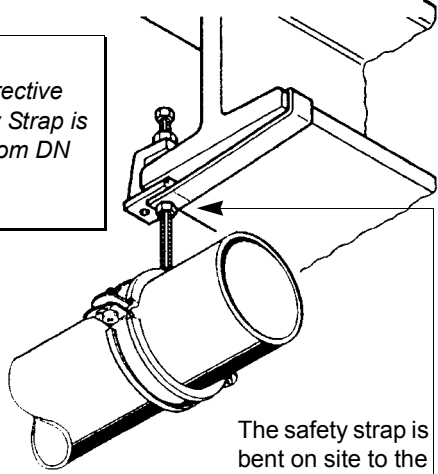

The safety strap is bent on site to the form of the beam, so that it securely encompasses the edge of the beam flange.

Inverted application

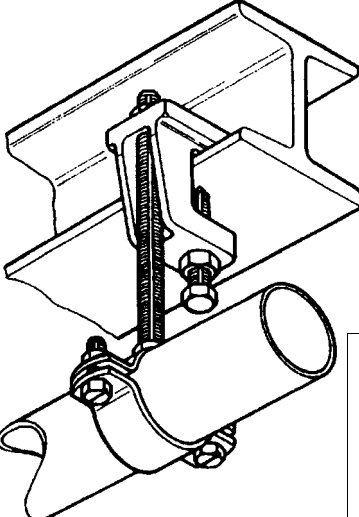

Caution!

► This arrangement is allowed for parallel-flange beams only

Standing arrangement

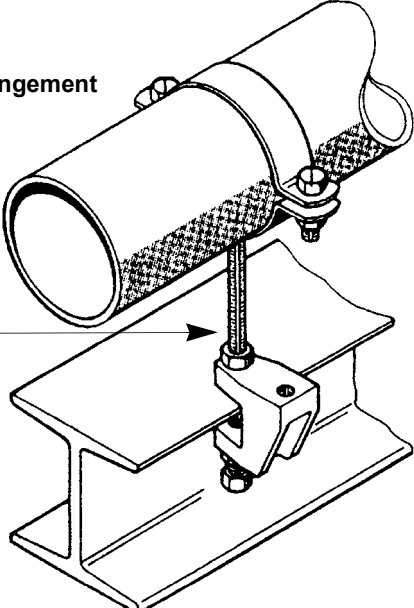

Projecting length of rod not to exceed 10 x rod diameter

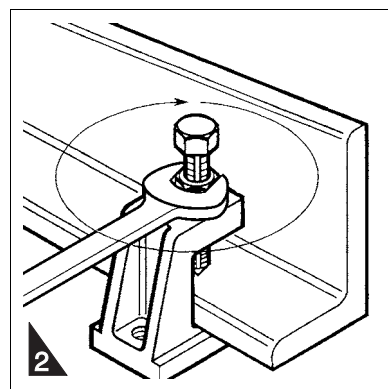
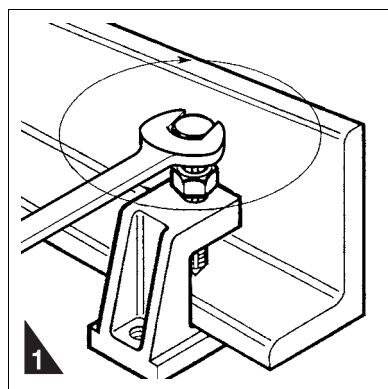

Caution!

► Take note of the torque:
 TCS 0: Rotate 1 revolution
 TCS 1 and TCS 2:
 Rotate min. 1 up to max. 1 1/2 revolutions.
 Then tighten locking nut.

Universal Joint for any variable Angle Adjustment

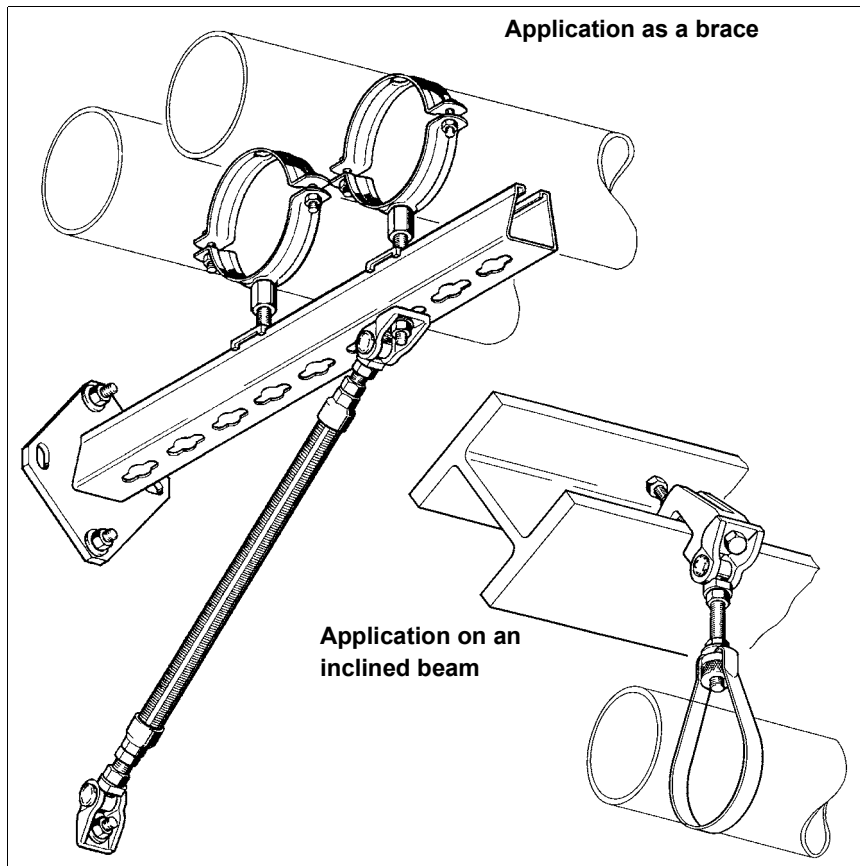

Braces can be installed with variable angles to their supporting surfaces. The combination with adapters allows for bracing arms with cross-sections up to Threaded Tube G1".

Application on an inclined beam

The pivot head in the Universal Joint can rotate freely, allowing adjustment to any angle.

Tightening the locking nut against the adapter plate locks the position.

Caution!

► In cases of dynamic loads it is necessary to secure the Beam Clamp TCS using a Safety Strap, possible in connection with another Beam Clamp TCS.

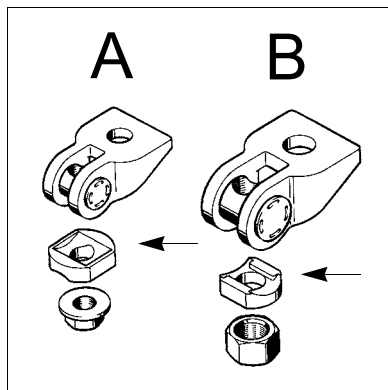

Figure A:

Type:
UG M8
UG M10

Figure B:

Type:
UG M12
UG M16
UG FP M12
UG FP M16

During installation, make sure the correct side of the adapter plate faces towards the body of the Universal Joint.

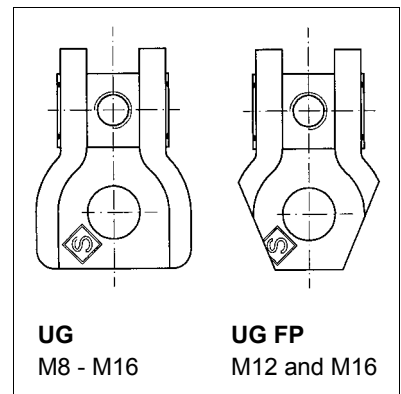

UG
M8 - M16

UG FP
M12 and M16

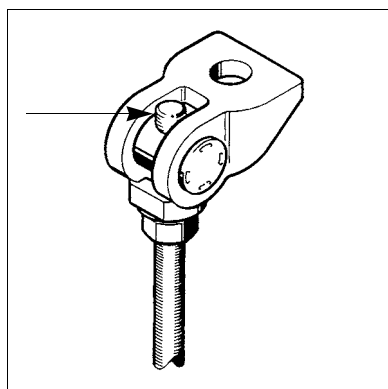

Note:

► The Threaded Rod must be clearly visible after being screwed into the pivot head.

Note:

► Refer to VdS CEA directives for the recommendation of supporting thread sizes for Sprinkler pipes.

Nominal size (NW)	Thread
≤ DN 50	M 8
> DN 50 - ≤ DN 100	M10
> DN 100 - ≤ DN 150	M12
> DN 150 - ≤ DN 200	M16

Beam Clamp TCS for Header Rails

with Beam Clamp TCS 41

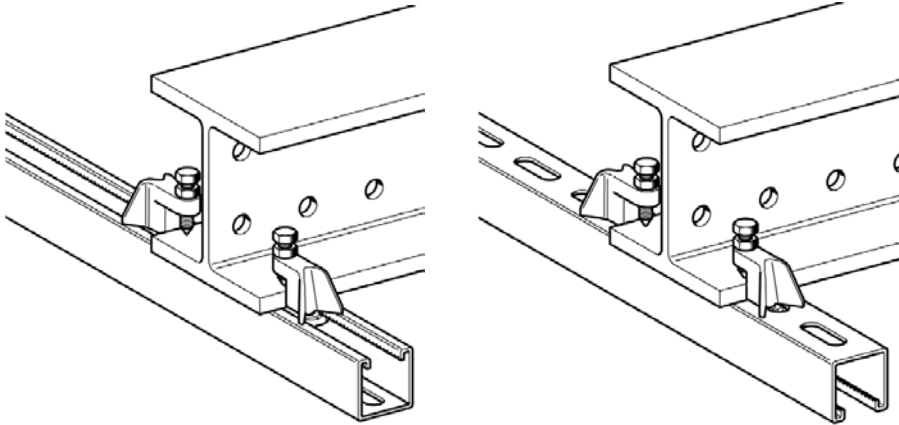

Beam clamps can attach into either the open face or rear slots of the channel, leaving the channel unobstructed for further installations.

with Beam Clamp TCS 0; 1; 2

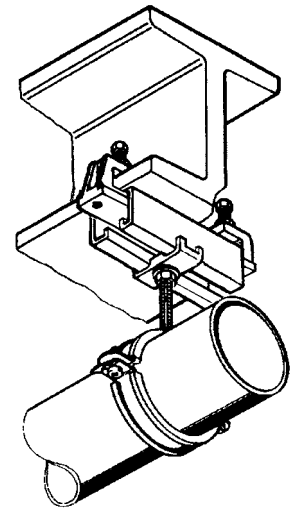

Cantilever arrangement with Beam Clamp TCS 1

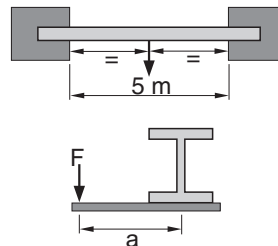
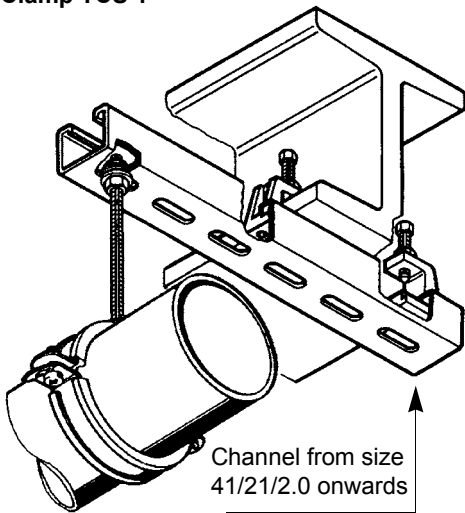

$$F_{zul} = \frac{M_b}{a}$$

$$\sigma_{perm} \leq 160 \text{ N/mm}^2$$

$$f_{perm} \leq 2 \text{ mm}$$

Sample:
Beam shape IPB 160
and distance A = 50 cm

Note:

► In cantilever arrangements, the permissible bending moment of the beam must not be exceeded.

Beam	permissible bending moment M_b [Nm]
IPB 100	50
IPB 140	115
IPB 160	180
IPB 200	310
IPB 240	540
IPB 300	970
IPB 340	1350

$$F_{perm} = \frac{180 \text{ Nm}}{0,5 \text{ m}} = 360 \text{ N}$$

Vertical pipe on vertical beam
-single support-

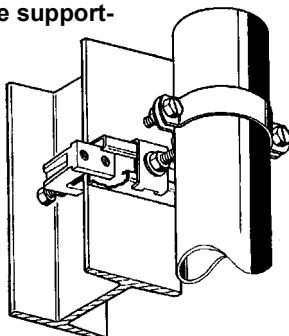

Caution!

► T-Head Bolt and Holding Bracket must be used! This arrangement requires Sikla Channel 41/21 or larger. Check permissible loadings by referring to the catalogue!

Horizontal pipe
-twin mounting-

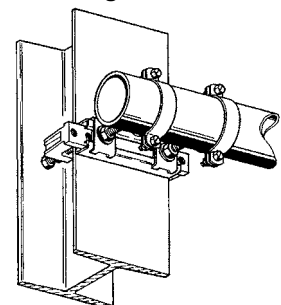

Beam Clip for Cross Support/ Dimensioning of Bolts

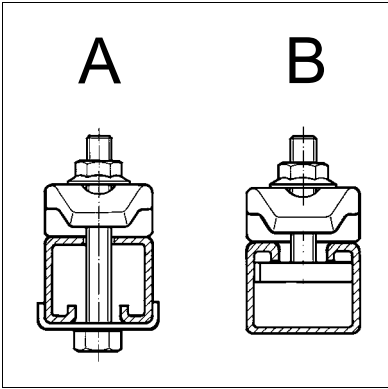
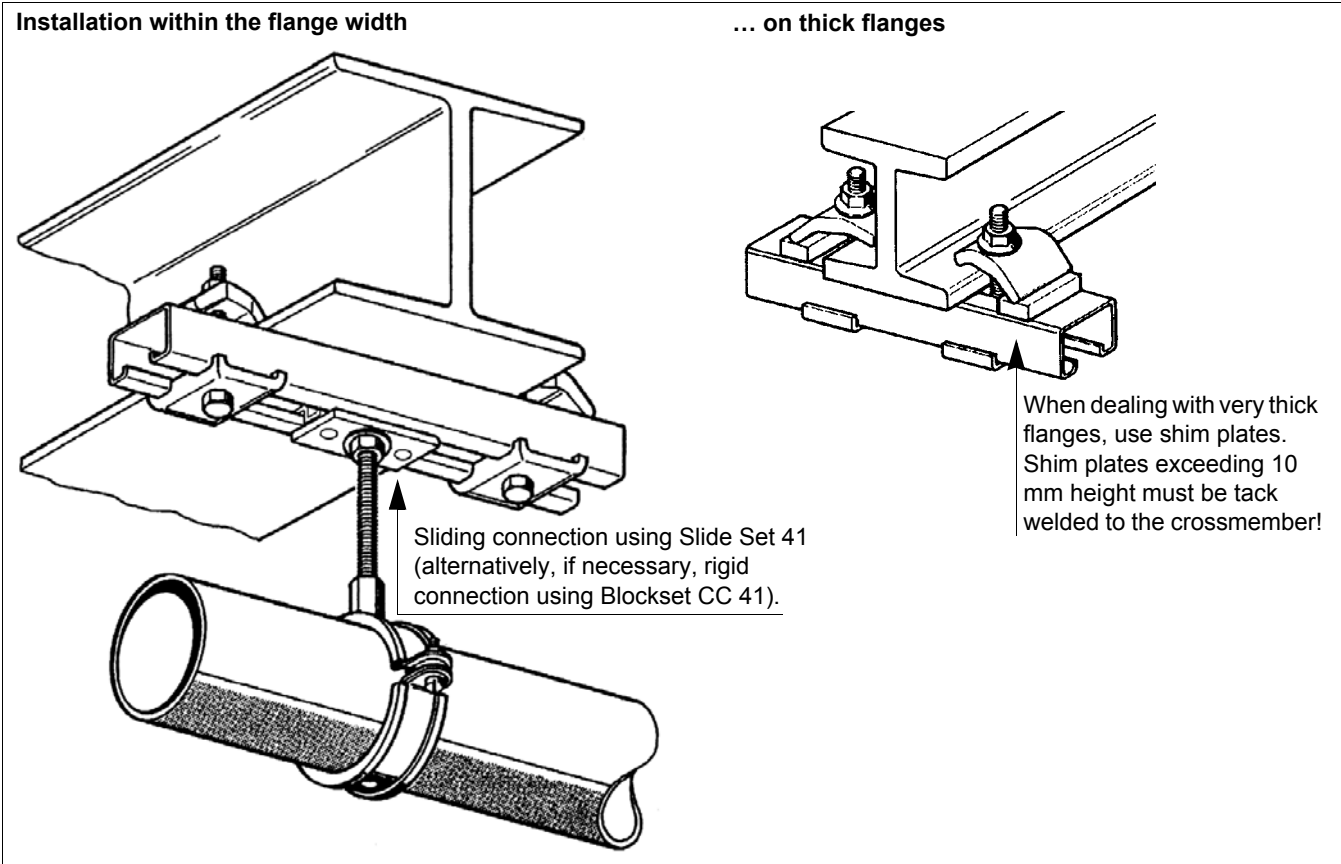

Installation

Determination of the required bolt length L_{min} :

Arrangement **A**
(with Hexagon Bolt)

- P1: $L_{min} = a + b + 37$ [mm]
- P2: $L_{min} = a + b + 43$ [mm]
- P3: $L_{min} = a + b + 48$ [mm]
- P4: $L_{min} = a + b + 55$ [mm]

Arrangement **B**
(with T-Head Bolt)

- P1: $L_{min} = b + 40$ [mm]
- P2: $L_{min} = b + 45$ [mm]
- P3: $L_{min} = b + 50$ [mm]
- P4: $L_{min} = b + 60$ [mm]

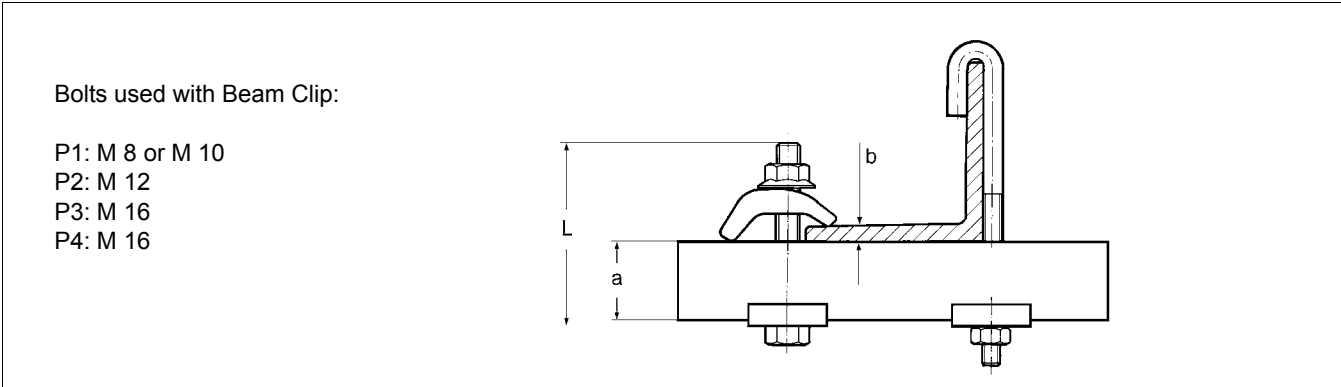

Beam Clip for Cross Member Support

Tandem cross support using
Channel 41-75/65/3.0 D

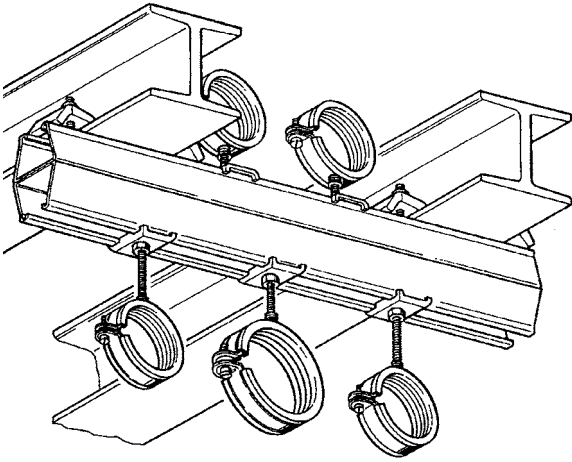

Cross member supported by opposing
web faces of 2 beams

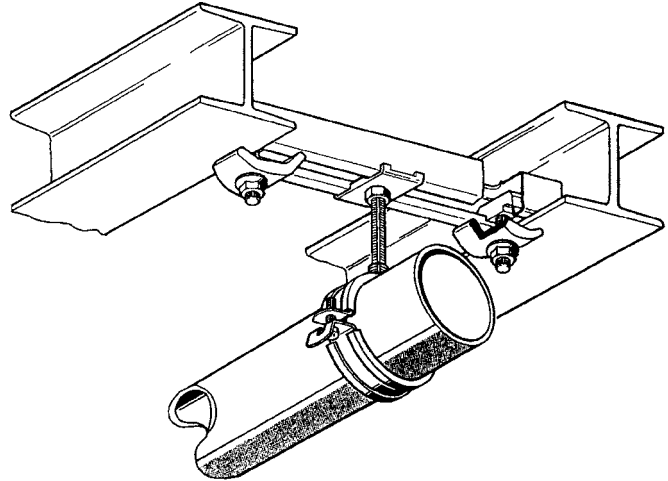

Installation of a duct
-suspended arrangement-

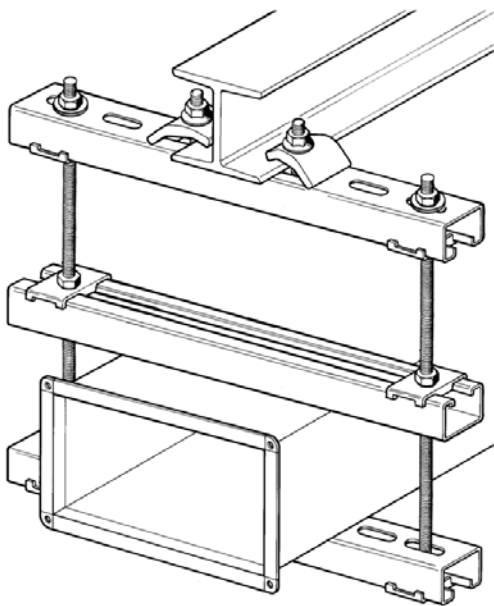

Installation of a duct
-directly below the beam-

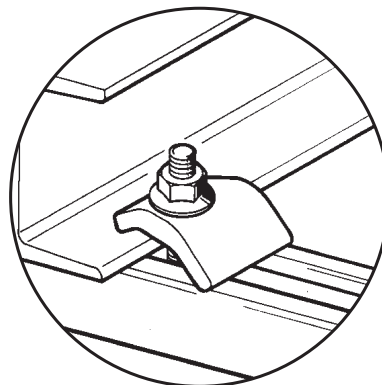
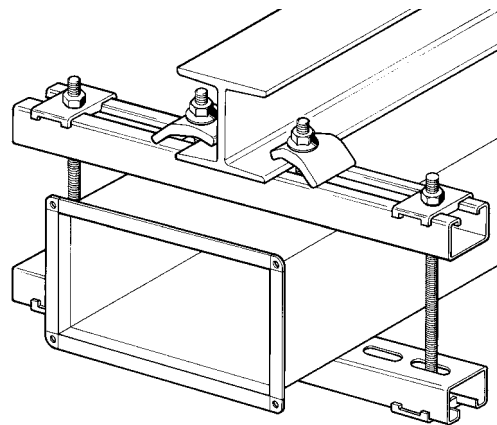

Note:

- ▶ When using Beam Clips, always make sure that
 - the wider side is located at the Channel and
 - the smaller side at the beam.

Beam Clip for Cantilever Support

Arrangement with U Bolt

Note:

- ▶ Use U Bolts only as guides. If they have to bear some vertical loads, U Bolts type DIN 3570 must be used.

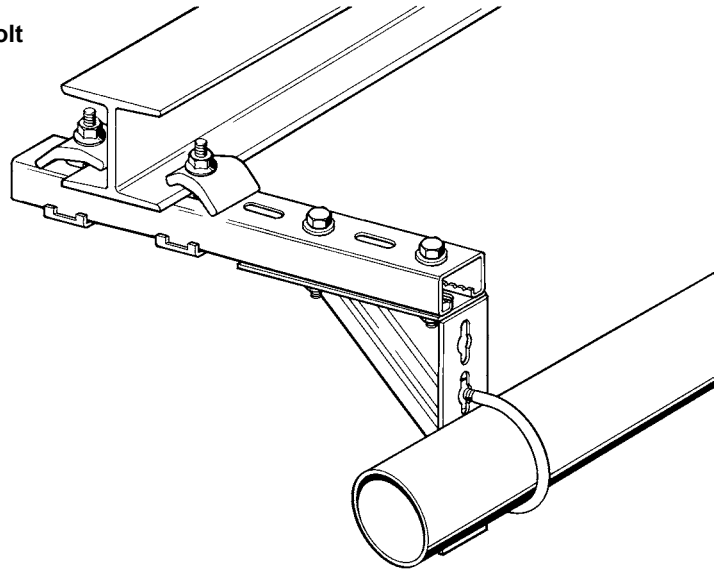

Caution!

- ▶ The permissible bending moment of the beam must not be exceeded!

Double-sided cantilever crossmember

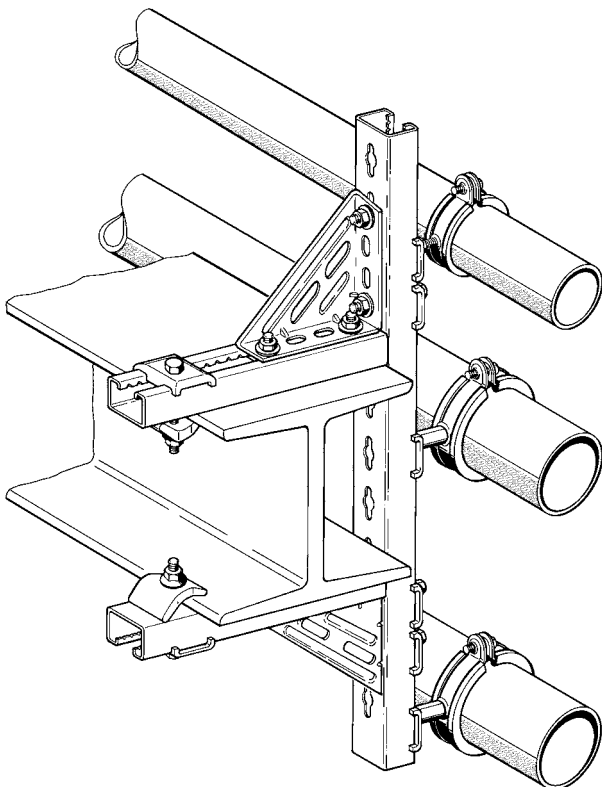
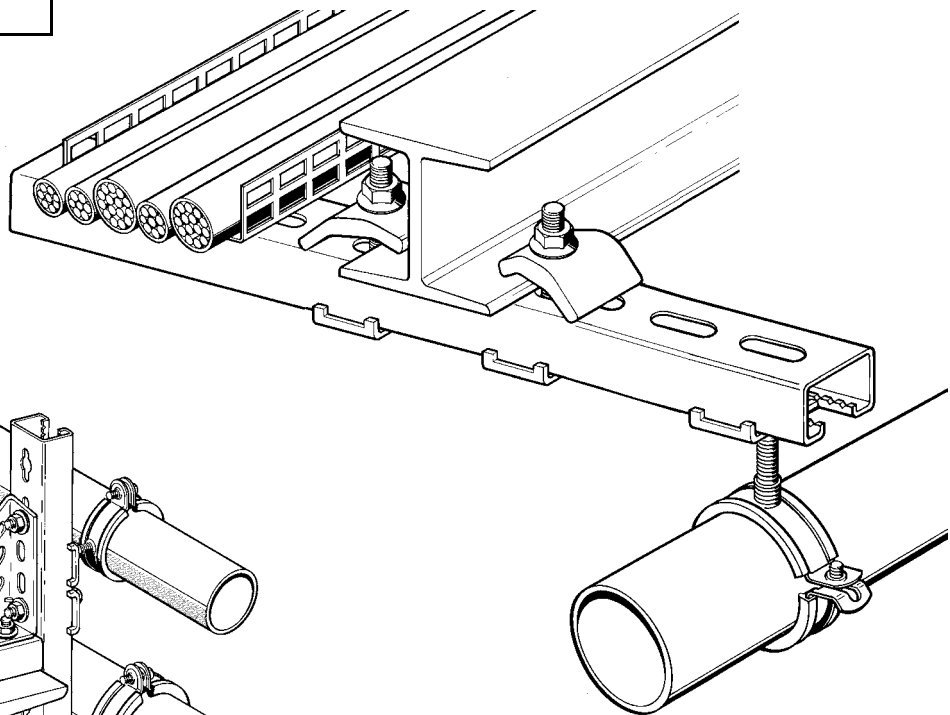

Combination of Support Bracket and Channel with horizontal pipes running parallel to the IPB beam. When using this arrangement, make sure that no axial forces from the pipes exist, which may cause the supporting frame to twist.

Beam Clip for Supports on Building Structures

Installation to cast-in channel

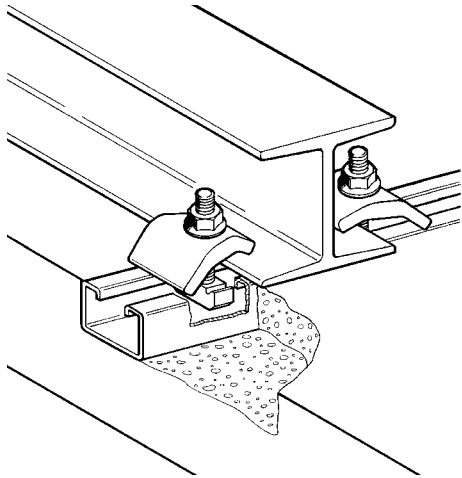

Installation with anchors

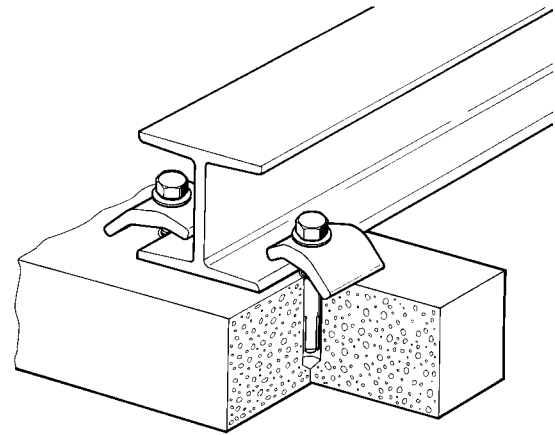

Installation on a timber support

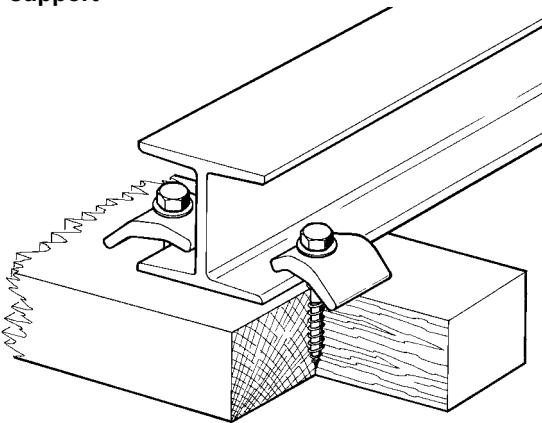

Fixing of a timber joist to a steel beam

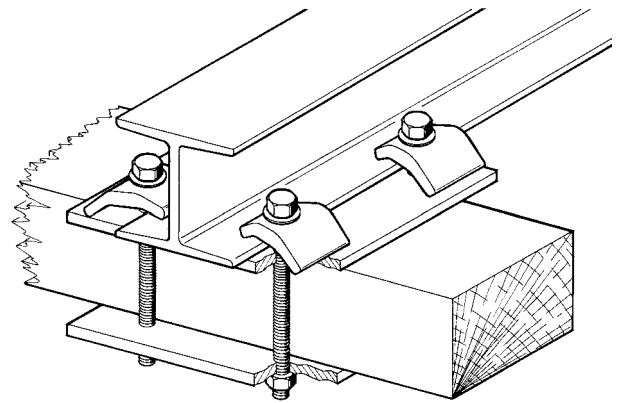

Fixing two beams crossing each other

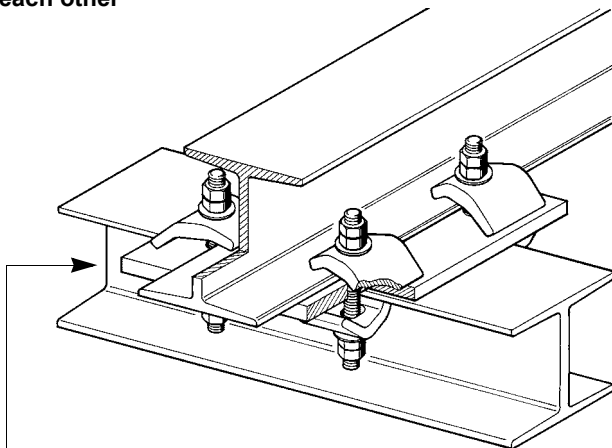

Simotec Base Plate GPL can be used between the two beams.

Pipe running directly below the beam

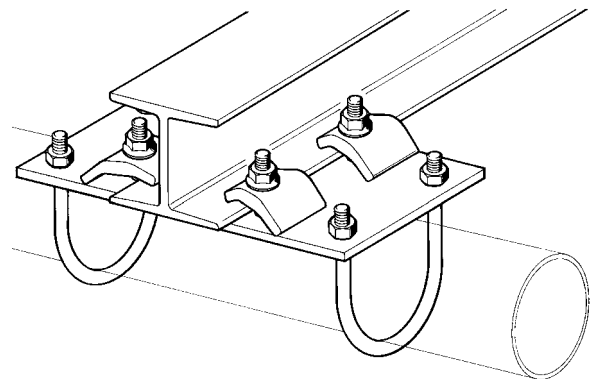

U-Holder SB 41

Arrangement above or below the beam

In all arrangements, the loading capacity of the beam has to be considered. In cantilever arrangements especially the torsional stiffness has to be considered

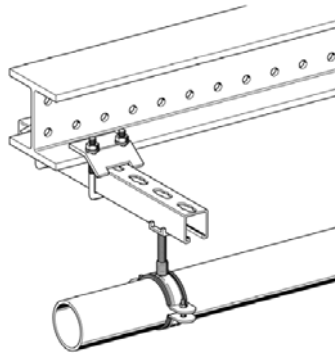

Loading capacity per U-Holder SB 41 M10 on horizontal beam up to max. 5kN.

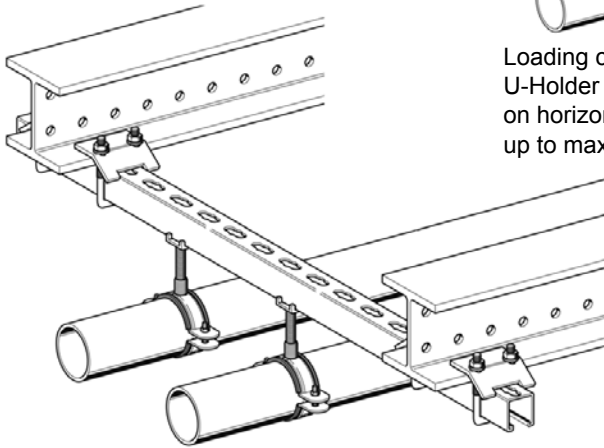

Calculation of loading capacity for horizontal beam with Sikla Structural Analysis Software SiPlan.

Direct installation of all rectangular single and double channels system 41 on steel beams with flange height up to max. 16 mm.

Note:

► U-Holder SB should always be used in pairs.

For secure support a minimal overhang of 50 mm is necessary.

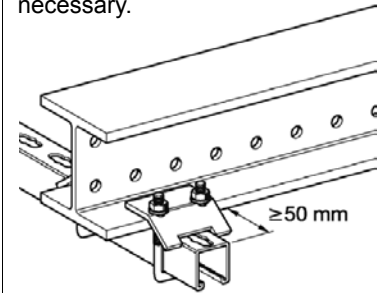

Lateral arrangement on the beam

Due to the geometry of the U-Holder, it is also possible to install Channels MS 41/41 and 41/21 D 90° rotated.

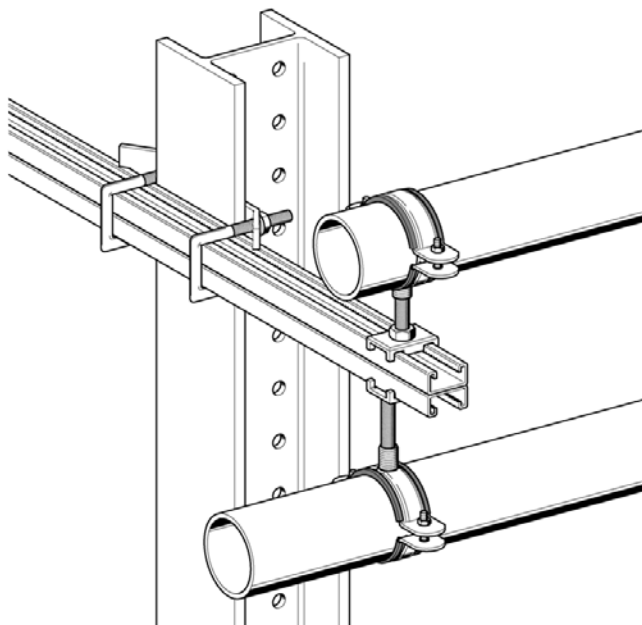

Type 41 D for profiles as of 41/41 D.

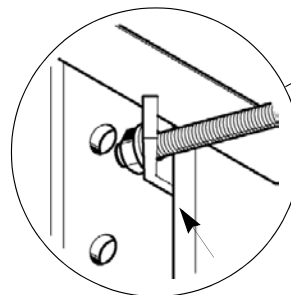

Caution!

► In lateral arrangement secure U-Holder against slipping (e.g. with 2 x TCS).

Threaded Hooks GH for Cross Supports

... hooked onto angle irons

... hooked onto steel C-sections

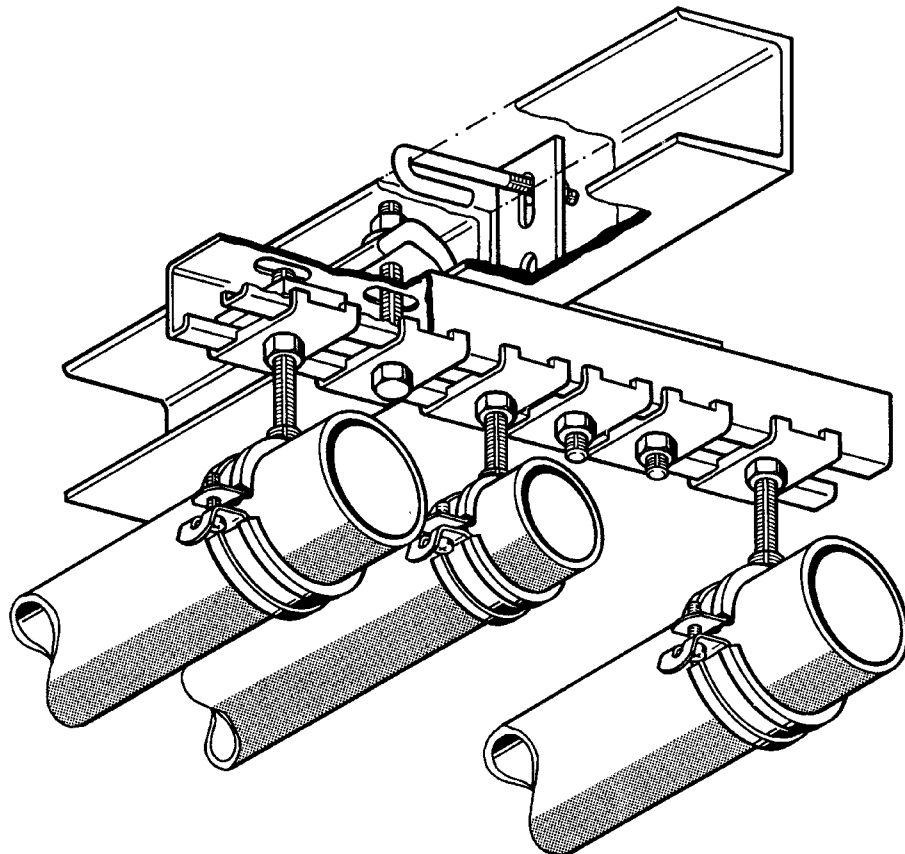
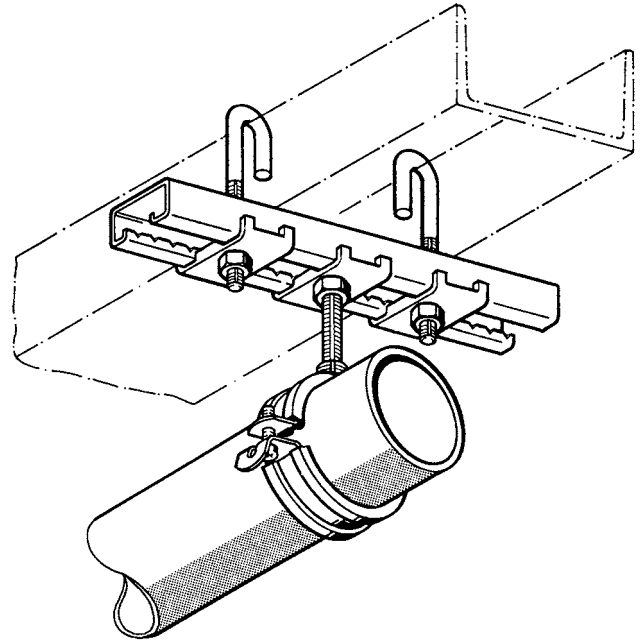
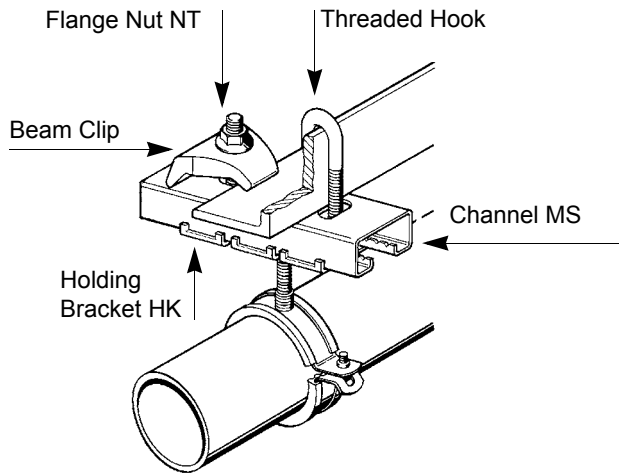

Hook Sleeves SP and Bulb Flat Steel Beam Clamp for single supports

Hook sleeves may be attached to flanges of C-section or Ibeam steelwork in cases when the beam is rotated through 90°

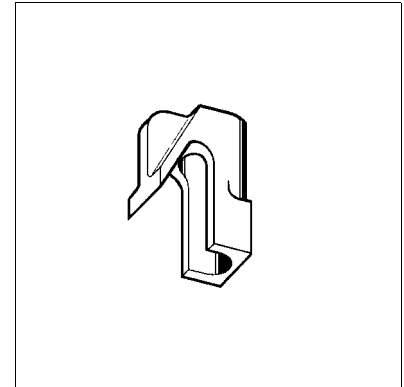
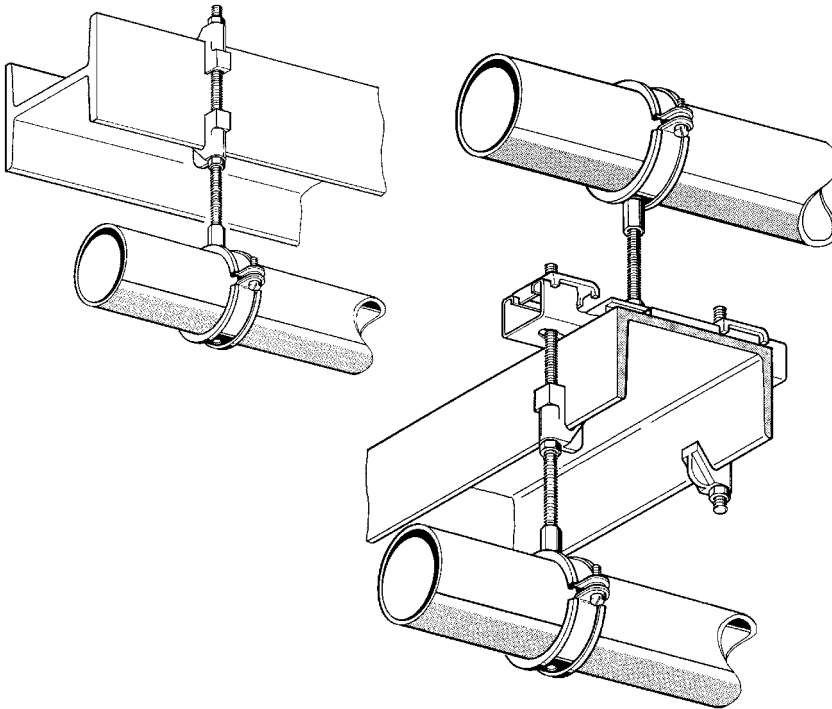

The Threaded Hook has a hole $\varnothing 13\text{mm}$ and is therefore suitable for Threaded Rods GST M8, M10, M12. If used with a M8 Threaded Rod, a Flange Nut NT is required.

Caution!

The load values stated in the catalogue refer only to the Hook Sleeves. The load capacities of the supporting beam or building structure must be checked separately.

Installation to Bulb Flat steel (HP-profile)

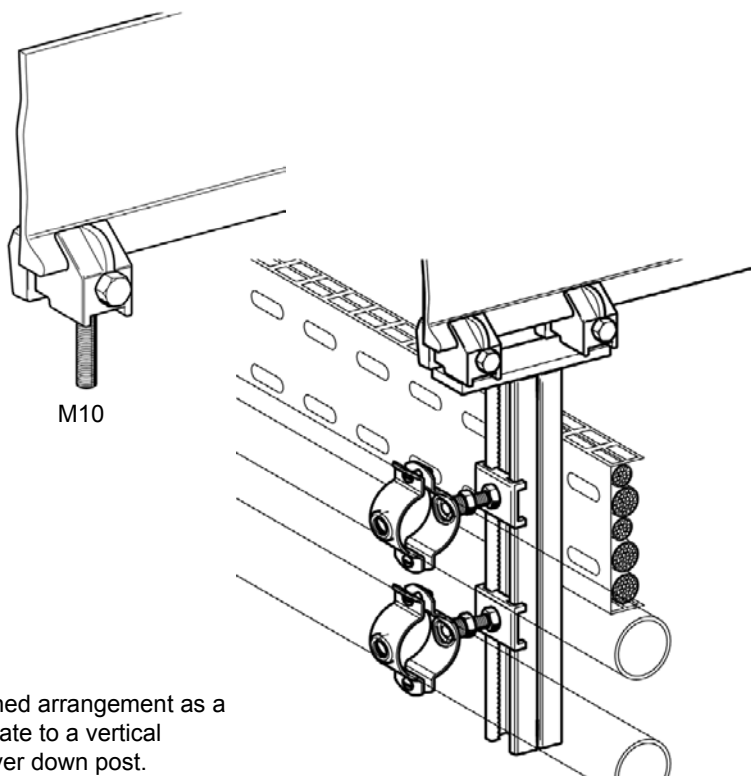

M10

Combined arrangement as a base plate to a vertical cantilever down post.

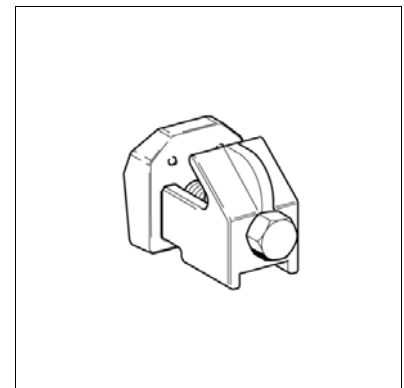

The Bulb Flat Beam Clamp is a solid connection element to fix pipework and electrical containment services to bulb flats HP (80 x 6 up to 160 x 6).

Hook Sleeves and Bulb Flat Beam Clamp for bracket installation

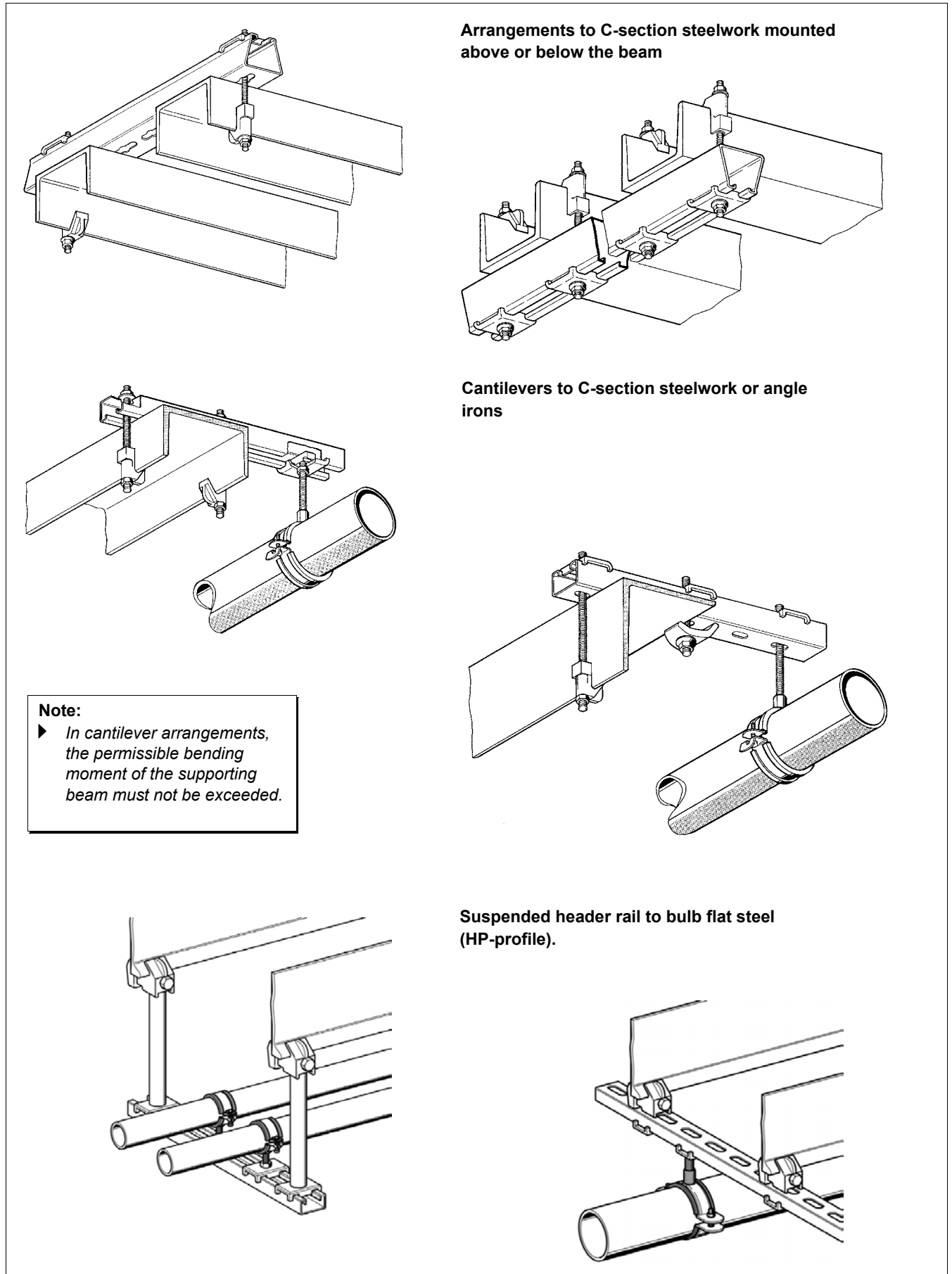

Arrangements to C-section steelwork mounted above or below the beam

Cantilevers to C-section steelwork or angle irons

Note:
 ▶ In cantilever arrangements, the permissible bending moment of the supporting beam must not be exceeded.

Suspended header rail to bulb flat steel (HP-profile).

Clamping End set SKL for Installation to I-beam and C-section profiles between flanges

Vertical beam and horizontal pipe run

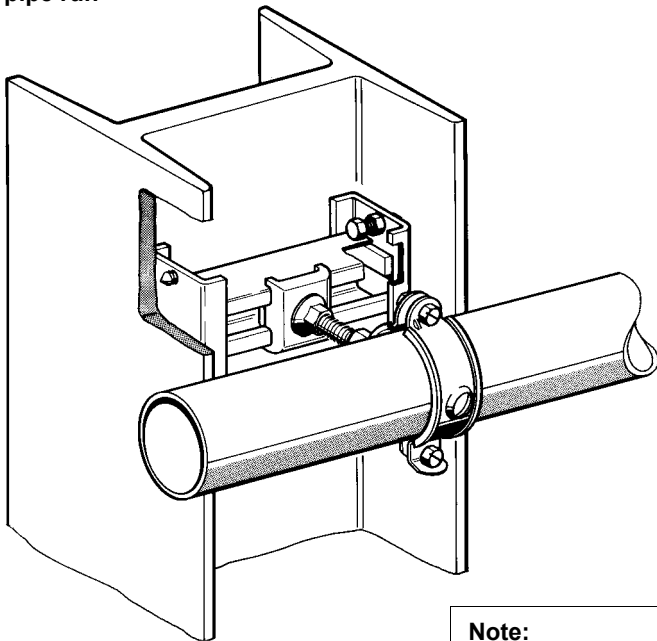

Pipe run parallel to the beam

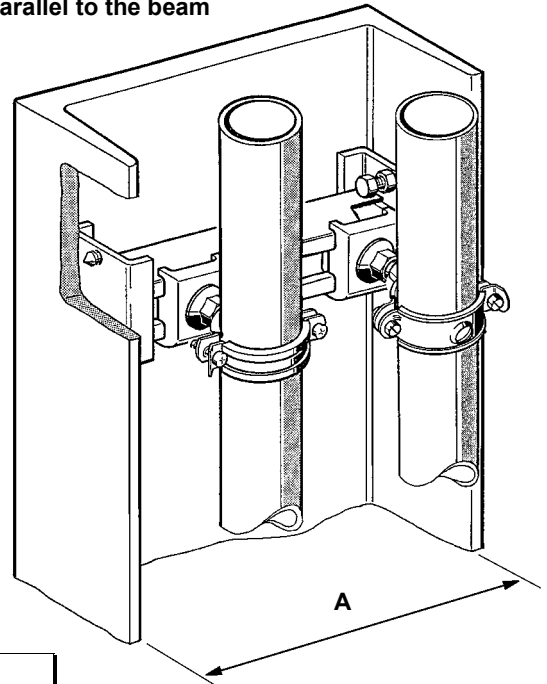

Note:

- ▶ Each Clamping End set SKL consists of two identical clamping plates. The support Channel between the end plates has to be cut to length on site. Fix the SKL set as deep as possible within the beam profile.

Note:

- ▶ Bolting torque: min. 1 up to max. 1 1/2 rotations
Lock after tightening!

Caution!

- ▶ Excess tightening of the point screws may result in deformation of the beam.

Cutting length

of the Channel = $A - 25 \text{ mm}$

A = clearance between the flanges

Suitable for beams with
A = 150 ... 800 mm

To be used in combination with
Channels 41/41/2.5 or 41/45/2.5
and Holding Brackets HK 41.

Cross-member support from webs between two opposing beam faces

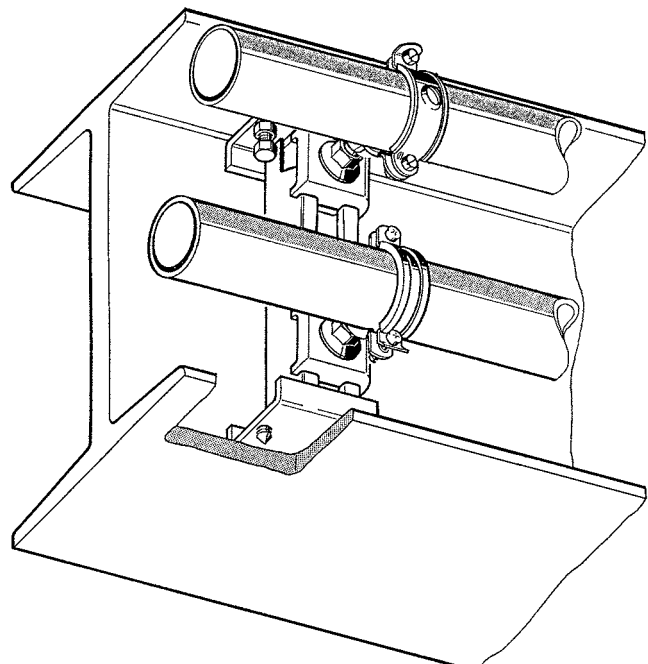
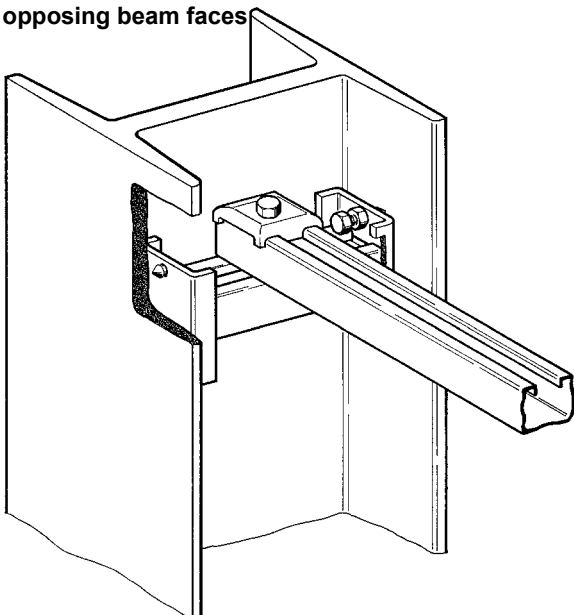

Toggle Stud KD for Installation to profiled Metal Decks

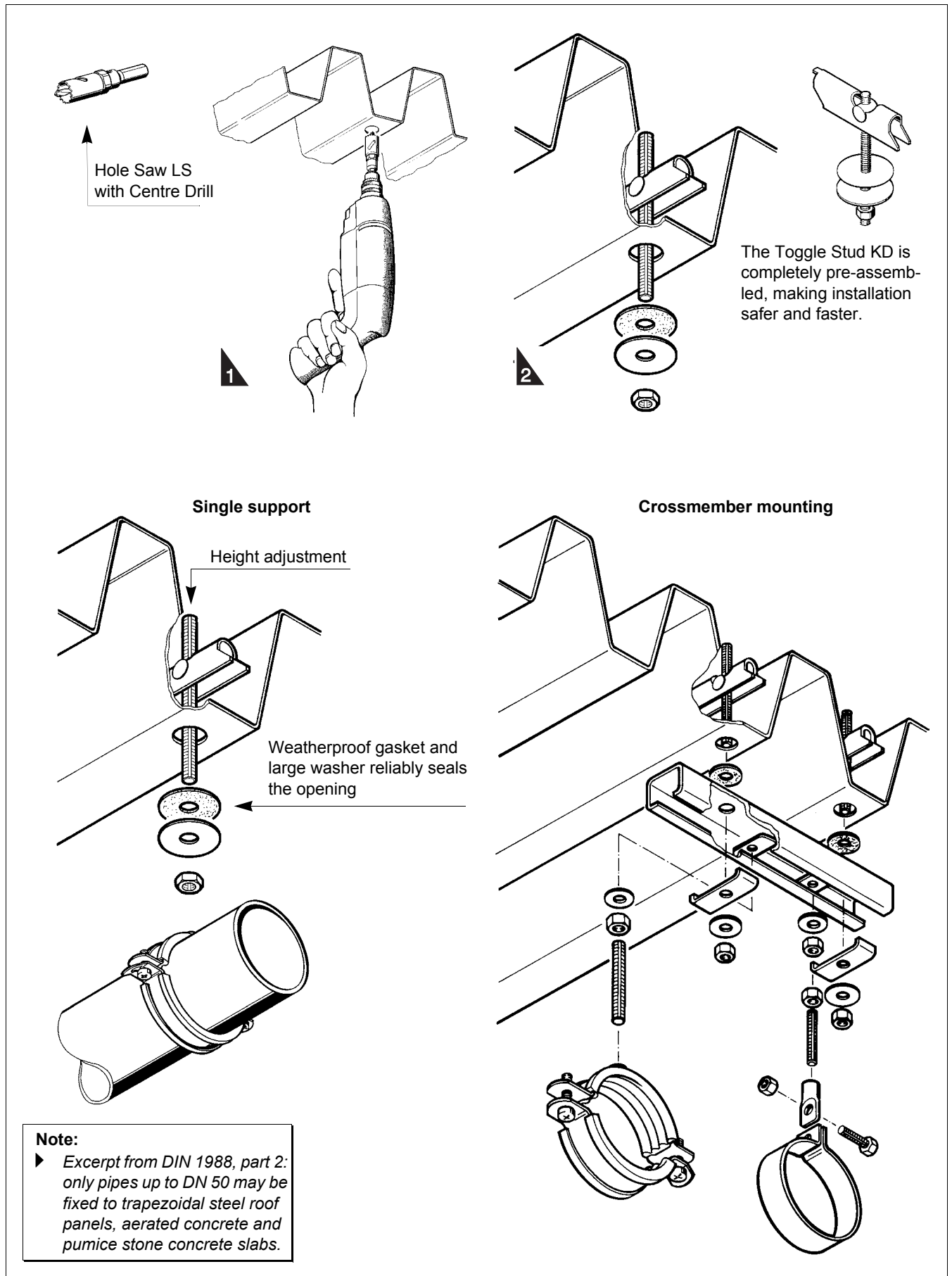

Roof Hangers TRH for Installation to Profiled Metal Decking

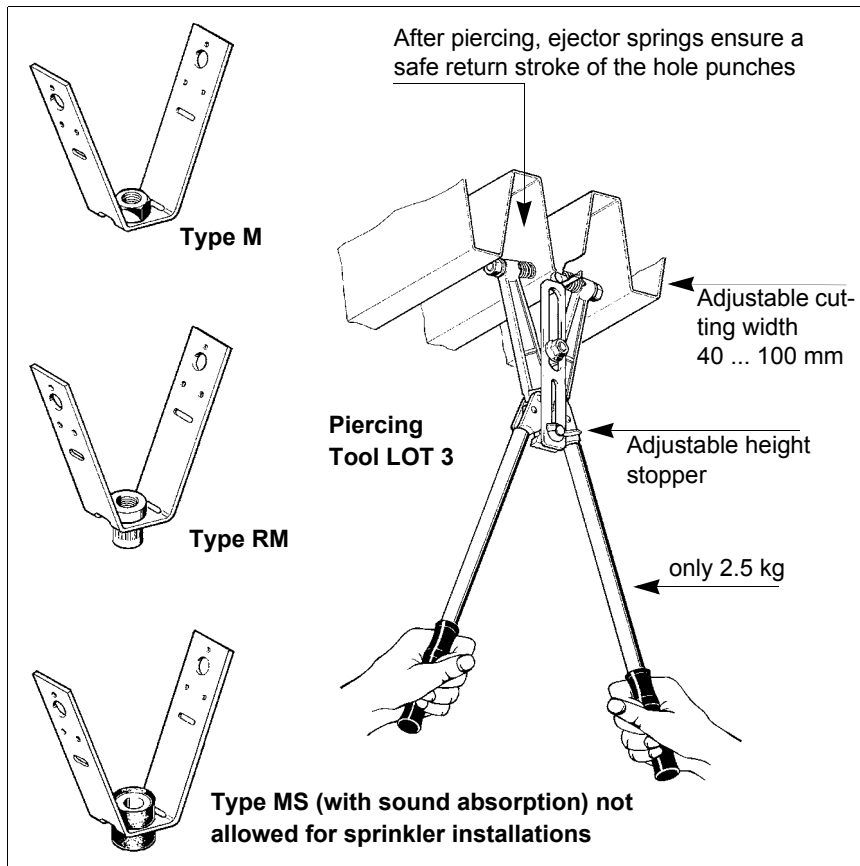

Note:

▶ Excerpt from DIN 1988, part 2: only pipes up to DN 50 may be fixed to trapezoidal steel roof panels, aerated concrete and pumice stone concrete slabs.

Height of perforation does not affect the loading capacity of the Roof Hanger TRH.

The greater the distance between the perforation and the bottom edge of the profile, the greater the stability of the Metal Decking Sheet.

Note:

▶ According to the VdS guidelines for sprinkler installations, all bolting has to be locked, e.g. with a locking nut at the horizontal bolt.

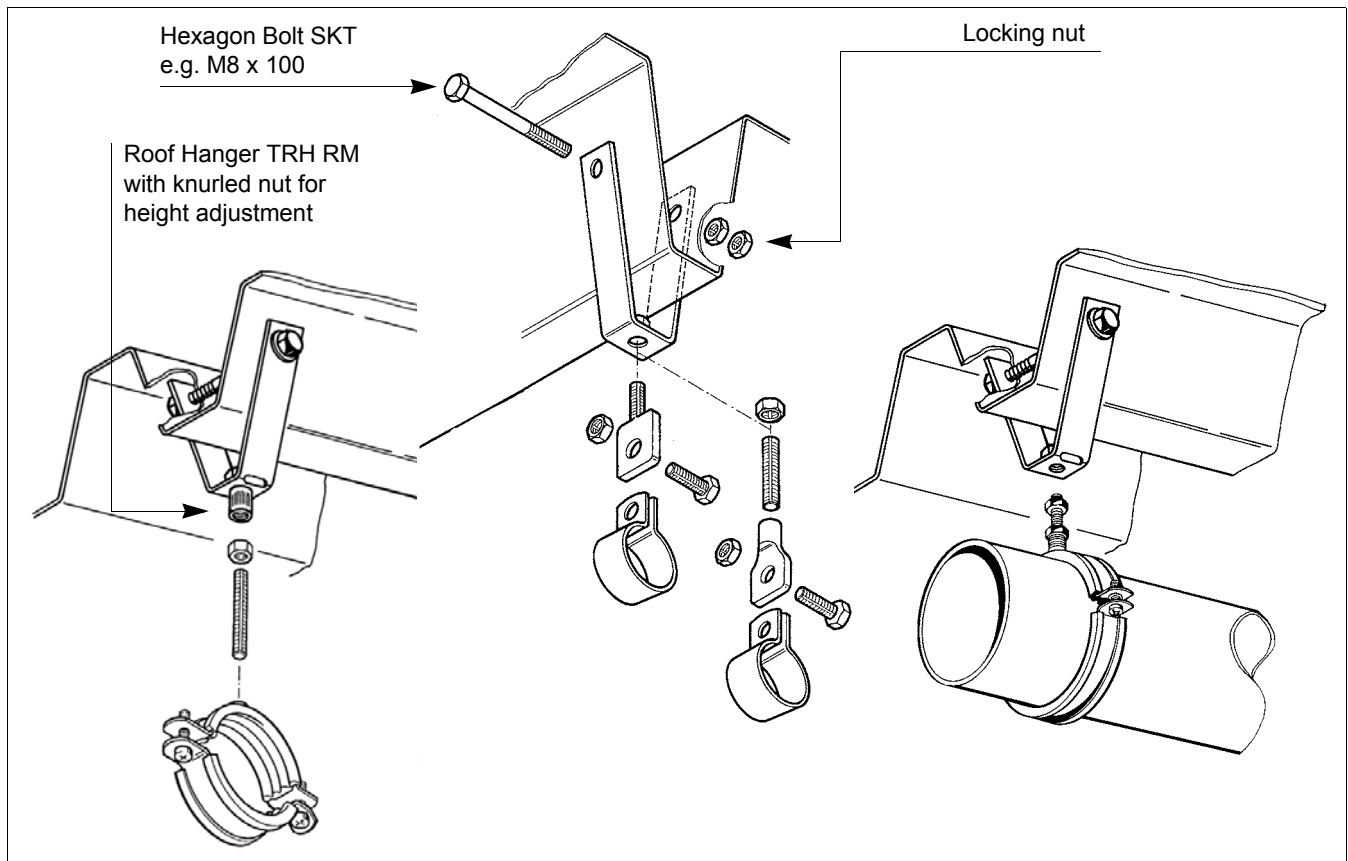

Fixing to Holorib and Cofrastra composite floors

